

# STARMAX

The world's leading battery brand



## DEEP CYCLE GEL BATTERIES

STG12-85 (12V 85AH)



[www.starmaxbatteries.com](http://www.starmaxbatteries.com)

# STG SERIES-GEL BATTERIES

## STG12-85

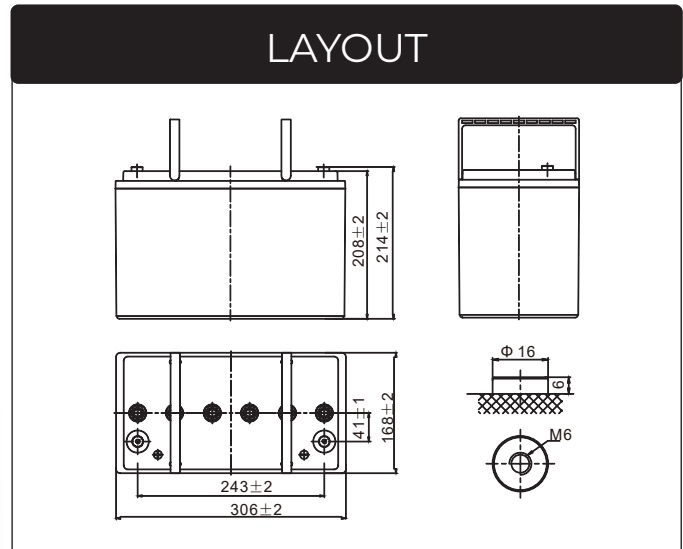

## General Features

- ✓ Battery design life up to 12 years
- ✓ Special plate design guarantees battery floating life more than 4000 times
- ✓ High thermal capacity reduce the risk of thermal out of control and drying hard, and the battery can be used in bad environment
- ✓ Little water losing, and no electrolyte stratification phenomenon

## Applications

- ✓ Telecommunications
- ✓ Solar system
- ✓ Wind power system
- ✓ Engine starting
- ✓ Wheelchair, Floor cleaning machines, Golf trolley, Boats

## Standards

- ✓ IEC 60896 Certified
- ✓ Classified as "Long Life" according to Eurobat
- ✓ UL, CE Certified
- ✓ Manufactured at Starmax® IATF16949, ISO 9001, ISO 8501 and ISO 45001 certified production facilities



# SPECIFICATIONS

Rated Voltage	12V	
Nominal Capacity	(C <sub>20</sub> ,1.80V/cell)	85Ah
Dimensions	Length	306±2mm (12.0 inches)
	Width	168±2mm (6.61 inches)
	Container height	208±2mm (8.19 inches)
	Total height	214±2mm (8.43 inches)
Approx. weight	27.5kg (60.6 lbs)	
Terminal	M6	
Container material	ABS	
Rated capacity (25°C)	85.0 Ah	C20(4.25A,1.80V/cell)
	80.4 Ah	C10(8.00A,1.80V/cell)
	75.0 Ah	C5(15.0A,1.75V/cell)
	67.2 Ah	C3(22.4A,1.75V/cell)
	53.8 Ah	C1(53.8A,1.60V/cell)
Max. discharge current	850A (5s)	
Internal resistance (25°C)	Approx 7.4mΩ	
Operating temp. range	Discharge	-20~55°C (-4~131°F)
	Charge	-20~40°C (-4~104°F)
	Storage	-15~50°C (5~122°F)
Nominal operating temp. range	25±3°C (77±5°F)	
Standby Use	Initial Charging Current less than 21.25A. Voltage 2.23V~2.27V at 25°C (77°F)Temp. Coefficient -3mV/°C	
Equalization Use	Initial Charging Current less than 21.25A. Voltage 2.30V~2.37V at 25°C (77°F)Temp. Coefficient -4mV/°C	
Cycle Use	Initial Charging Current less than 21.25A. Voltage 2.40V~2.50V at 25°C (77°F)Temp. Coefficient -5mV/°C	
Effect of temp. to Capacity	40°C (104°F)	103%
	25°C (77°F)	100%
	0°C (32°F)	86%
Self discharge	STG series batteries may be stored for up to 6 months at 25°C(77°F) and then a freshening charge is required. For higher temperatures the time interval will be shorter.	

### Constant Current Discharge (Amperes) at 25°C (77°F)

F.V/Time	10min	15min	20min	30min	45min	1h	1.5h	2h	3h	4h	5h	6h	8h	10h	20h
1.85V/cell	111.9	97.0	76.3	62.6	47.8	40.0	30.1	24.7	19.6	15.9	13.9	11.8	9.22	7.84	4.06
1.80V/cell	127.0	109.9	86.2	69.4	52.3	44.2	33.2	27.2	21.5	17.3	14.6	12.5	9.66	8.00	4.25
1.75V/cell	137.7	119.0	93.1	75.6	55.9	49.6	36.6	29.2	22.4	17.9	15.0	12.9	9.75	8.24	4.38
1.70V/cell	144.1	125.0	98.0	81.1	59.7	51.1	37.5	29.7	22.8	17.9	15.3	13.0	9.84	8.24	4.44
1.67V/cell	151.5	130.1	101.4	83.4	60.9	52.1	38.3	30.3	23.1	18.2	15.5	13.2	9.94	8.32	4.48
1.60V/cell	156.6	134.1	104.0	88.4	64.8	53.8	39.4	31.0	23.4	18.5	15.8	13.4	10.03	8.40	4.53

### Constant Power Discharge (Watts/cell) at 25°C (77°F)

F.V/Time	10min	15min	20min	30min	45min	1h	1.5h	2h	3h	4h	5h	6h	8h	10h	20h
1.85V/cell	210.4	183.6	145.1	120.8	92.7	77.7	58.6	48.3	38.5	31.3	27.4	23.4	18.2	15.5	8.08
1.80V/cell	235.4	205.4	162.3	132.4	100.5	85.3	64.3	52.9	42.0	33.9	28.7	24.7	19.0	15.8	8.44
1.75V/cell	251.2	219.2	173.2	143.0	106.9	95.0	70.4	56.4	43.5	34.8	29.4	25.5	19.2	16.3	8.69
1.70V/cell	258.2	227.2	180.0	151.5	113.2	97.1	71.8	57.2	44.1	34.7	29.7	25.5	19.4	16.3	8.80
1.67V/cell	268.4	234.2	185.0	154.7	114.8	98.7	73.0	58.2	44.6	35.2	30.1	25.8	19.5	16.4	8.97
1.60V/cell	272.2	237.5	187.6	162.5	121.3	101.0	74.4	59.0	44.8	35.7	30.6	26.0	19.6	16.5	8.98

## Discharge Characteristics

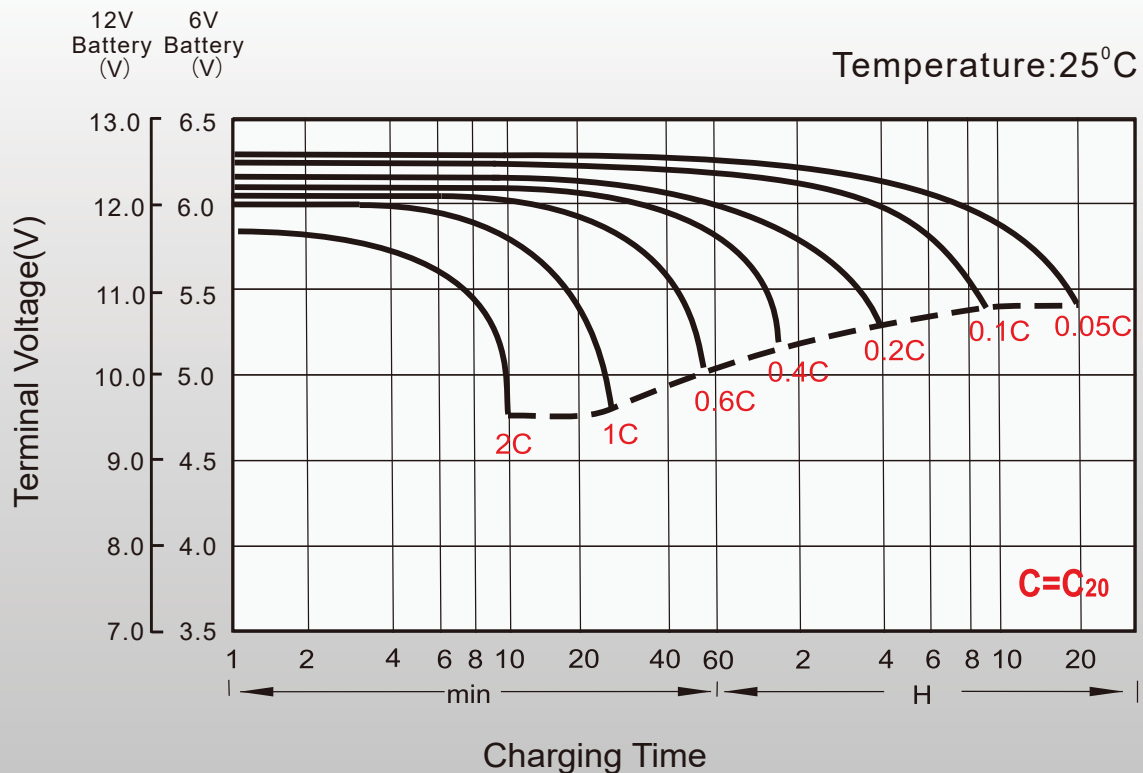

# Float Charging Characteristics

Charge Volume  
Charging Current  
Charging Voltage

0.1CA-2.25V/cell Temperature: 25°C

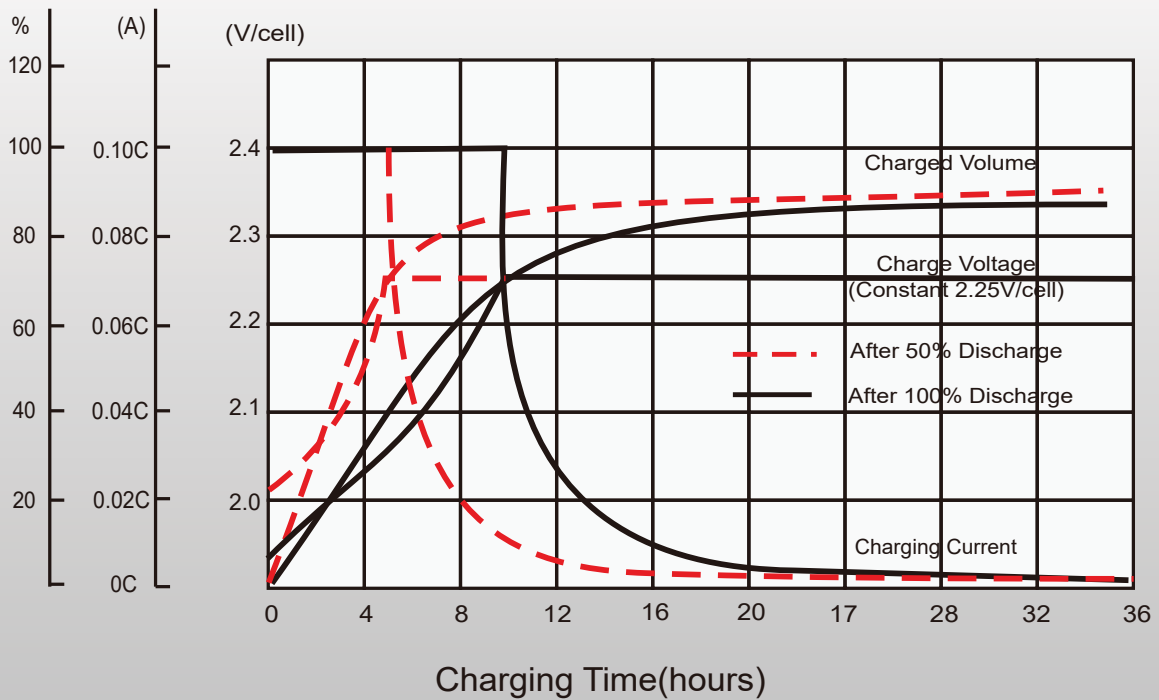

# Cycle Life in Relation to Depth of Discharge

Acc.to IEC 896-2 (25 °C / 77 °F)

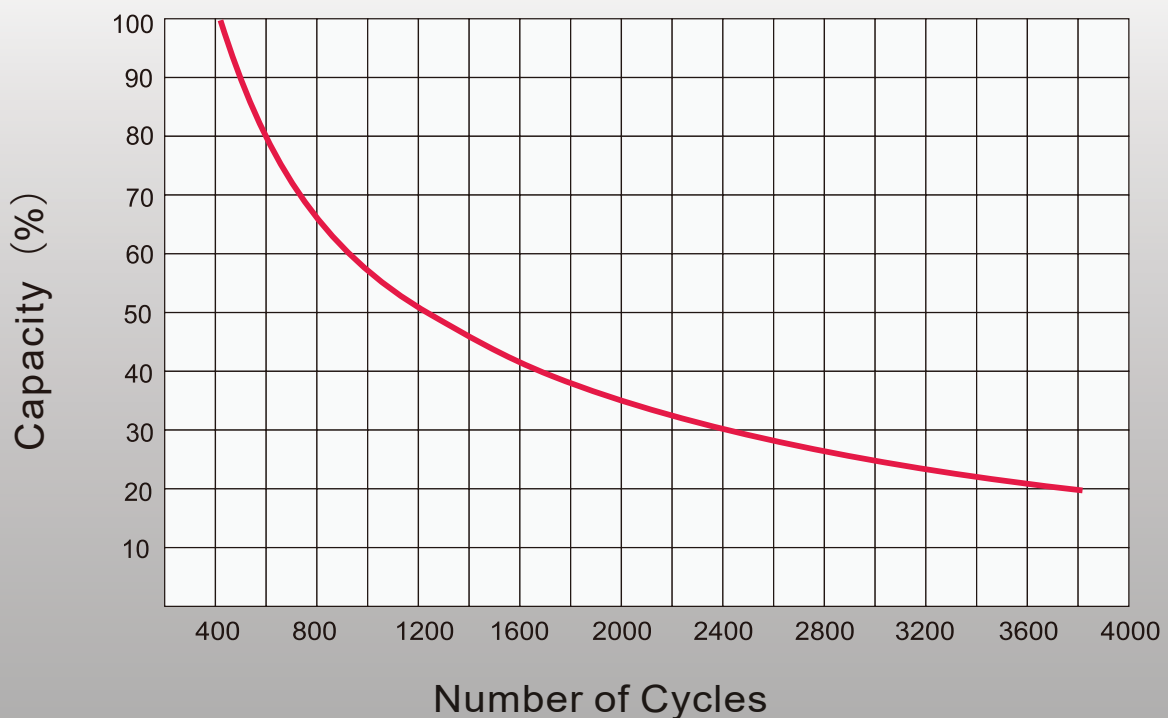

# Effect of Temperature on Long Term Float Life

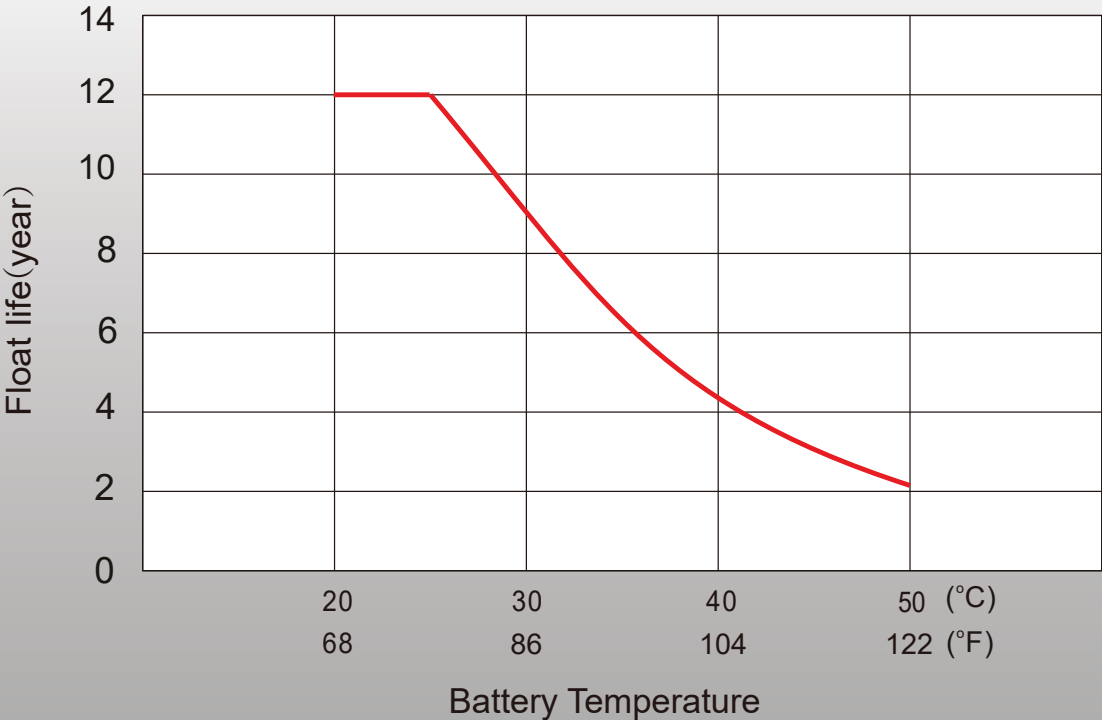



**Starmax Corporation**

1585 Cliveden Avenue, Delta, British Columbia  
V3M 6M1, Canada

**Phone:** +1 888 669 1310

**Email:** [info@starmaxbatteries.com](mailto:info@starmaxbatteries.com)

**Website:** [www.starmaxbatteries.com](http://www.starmaxbatteries.com)

