



# GENERAL PURPOSE **BATTERIES**

ST12-250 (12V 250Ah)



[www.starmaxbatteries.com](http://www.starmaxbatteries.com)

# ST SERIES - GENERAL PURPOSE

## ST12-250



### LAYOUT

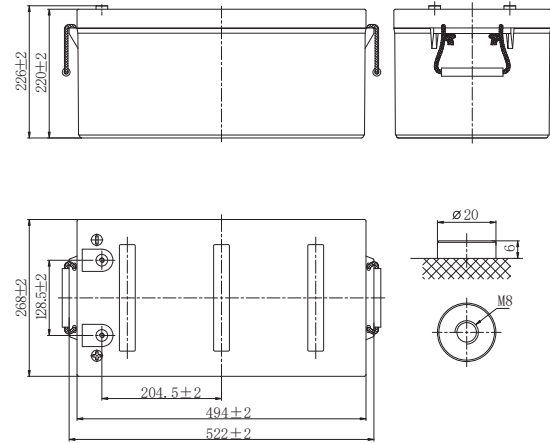

## General Features

- ✓ 10 years design life(25°C)
- ✓ Special exhaust structure and sealing technology, safe and reliable, flexible installation, convenient maintenance
- ✓ PbCaSn alloy for plate grids: less gassing, less self-discharging
- ✓ High quality AGM separator: extend cycle life and prevent micro short circuit
- ✓ High purity raw material: ensure low self discharge rate

## Applications

- ✓ All purpose
- ✓ Uninterruptable Power Supply (UPS)
- ✓ Electric Power System (EPS)
- ✓ Emergency backup power supply
- ✓ Alarm and security system
- ✓ Communication power supply
- ✓ DC power supply
- ✓ Auto control system

## Standards

- ✓ Compliance with IEC 60896 standards, EU Battery Directive
- ✓ UL, CE Certified
- ✓ Manufactured in Starmax® IATF16949, ISO45001, ISO 9001 and ISO 14001 certified production facilities



# SPECIFICATIONS

Rated Voltage	12V	
Nominal Capacity	250.0Ah	(C <sub>10</sub> ,1.80V/cell)
Dimensions	Length	522±2mm (20.55 inches)
	Width	268±2mm (10.55 inches)
	Container height	220±2mm (8.66 inches)
	Total height	226±2mm (8.90 inches)
Approx. weight	70.6 Kg (155.7 lbs)	
Terminal	M8	
Container material	ABS	
Rated capacity (25°C)	262.0 Ah	(20hr,13.1A,1.80V/cell)
	250.0 Ah	(10hr,25.0A,1.80V/cell)
	227.5 Ah	(5hr,45.5A,1.75V/cell)
	207.3 Ah	(3hr,69.1A,1.75V/cell)
	159.4 Ah	(1hr,159.4A,1.60V/cell)
Max. discharge current	2500A (5s)	
Internal resistance (25°C)	Approx 2.8mΩ	
Operating temp. range	Discharge	-15~50°C (5~122°F)
	Charge	-20~40°C (-4~104°F)
	Storage	-15~40°C (5~104°F)
Nominal operating temp. range	25±3°C (77±5°F)	
Cycle Use	Initial Charging Current less than 75.0A.. Voltage 14.4V~15.0V at 25°C(77°F)Temp. Coefficient -30mV/°C	
Standby Use	Initial Charging Current less than 75.0A.. Voltage 13.5V~13.8V at 25°C(77°F)Temp. Coefficient -20mV/°C	
Effect of temp. to Capacity	40°C (104°F)	103%
	25°C (77°F)	100%
	0°C (32°F)	86%
Self discharge	ST series batteries may be stored for up to 6 months at 25°C(77°F) and then a freshening charge is required. For higher temperatures the time interval will be shorter.	

### Constant Current Discharge (Amperes) at 25°C (77°F)

F.V/Time	10min	15min	20min	30min	45min	1h	1.5h	2h	3h	4h	5h	6h	7h	10h	20h
<b>1.85V/cell</b>	362.5	320.7	252.2	225.5	164.9	139.7	101.2	85.1	62.4	49.0	42.5	37.5	28.8	23.9	12.7
<b>1.80V/cell</b>	411.4	363.4	285.1	245.5	174.7	144.7	104.7	87.9	67.8	52.3	44.7	40.3	30.3	25.0	13.1
<b>1.75V/cell</b>	446.2	393.4	307.8	250.5	181.0	151.8	110.0	92.5	69.1	53.3	45.5	40.6	30.5	25.3	13.3
<b>1.70V/cell</b>	475.7	417.8	326.4	255.5	184.6	154.8	112.2	94.4	70.4	54.2	46.3	40.8	30.9	25.5	13.4
<b>1.67V/cell</b>	490.8	430.0	335.3	259.3	187.3	157.1	113.9	95.7	71.1	55.0	47.2	41.0	31.4	25.8	13.6
<b>1.60V/cell</b>	507.6	443.4	343.9	263.0	190.1	159.4	115.5	97.1	71.7	55.7	47.9	41.3	31.8	26.1	13.7

### Constant Power Discharge (Watts/cell) at 25°C (77°F)

F.V/Time	10min	15min	20min	30min	45min	1h	1.5h	2h	3h	4h	5h	6h	7h	10h	20h
<b>1.85V/cell</b>	641.2	582.9	460.5	413.7	304.4	259.3	188.4	158.9	117.1	92.3	80.4	71.1	54.9	45.6	24.2
<b>1.80V/cell</b>	717.3	652.0	515.0	446.8	320.3	267.2	193.9	163.3	126.5	98.1	84.2	76.0	57.6	47.6	25.1
<b>1.75V/cell</b>	765.6	695.9	549.7	452.4	329.9	279.1	202.9	171.2	128.6	99.6	85.3	76.4	57.7	48.1	25.2
<b>1.70V/cell</b>	804.8	731.5	577.9	457.6	334.2	283.1	206.0	174.0	130.7	101.0	86.5	76.7	58.6	48.5	25.5
<b>1.67V/cell</b>	817.9	743.4	587.3	460.9	337.2	285.7	208.0	175.7	131.3	102.1	88.0	76.8	59.2	49.1	25.8
<b>1.60V/cell</b>	829.4	753.9	595.6	462.8	338.9	287.8	209.7	177.1	131.8	102.9	88.9	77.1	59.9	49.5	26.0

## Discharge Characteristics

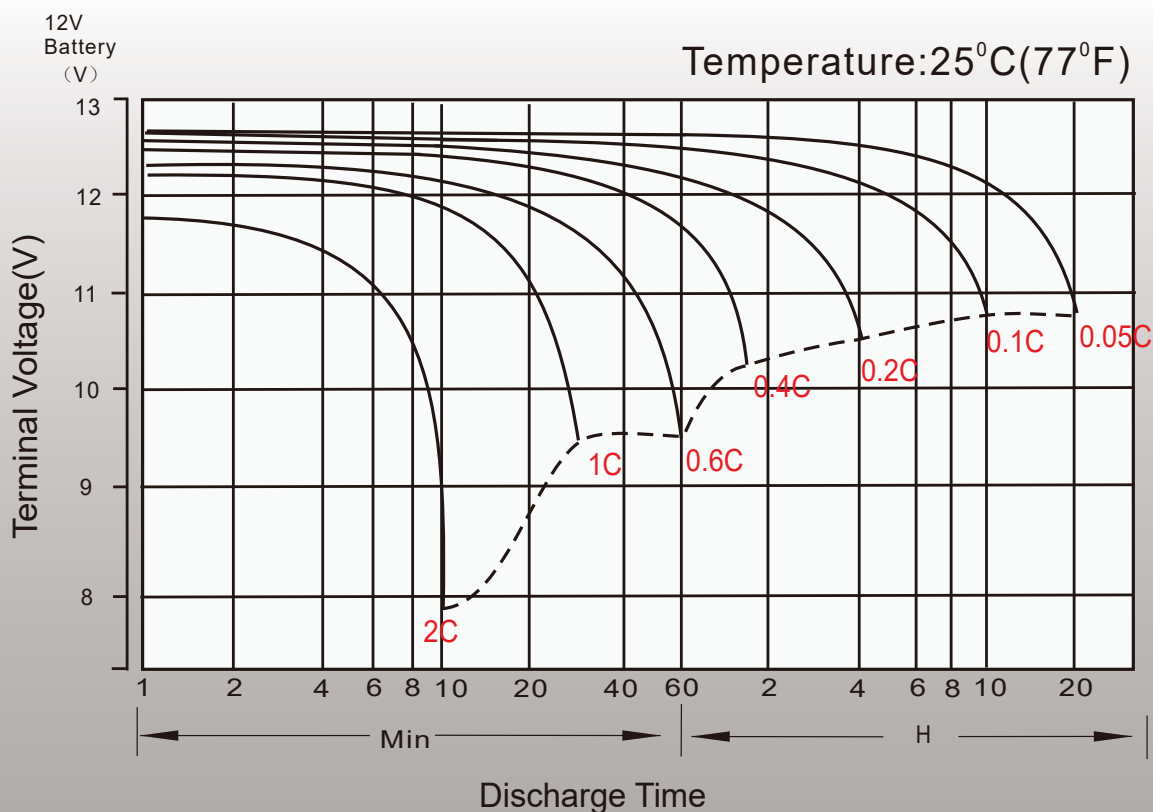

# Float Charging Characteristics

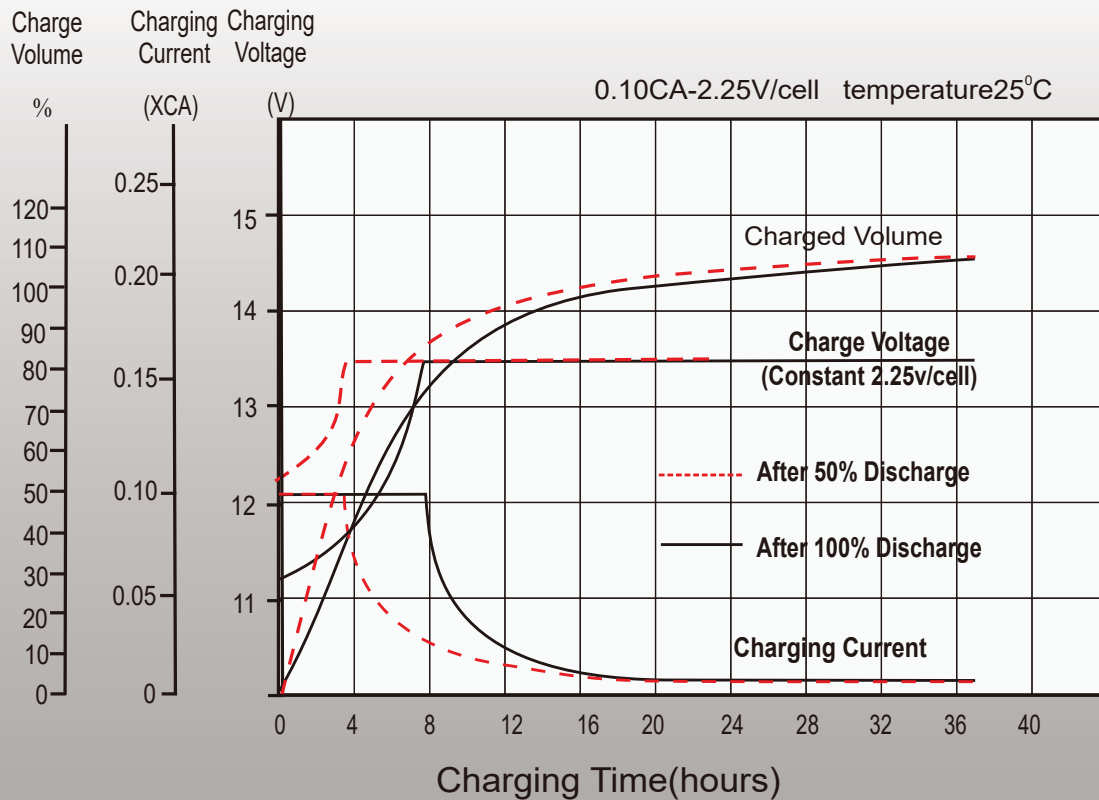

# Temperature Effects in Relation to Battery Capacity

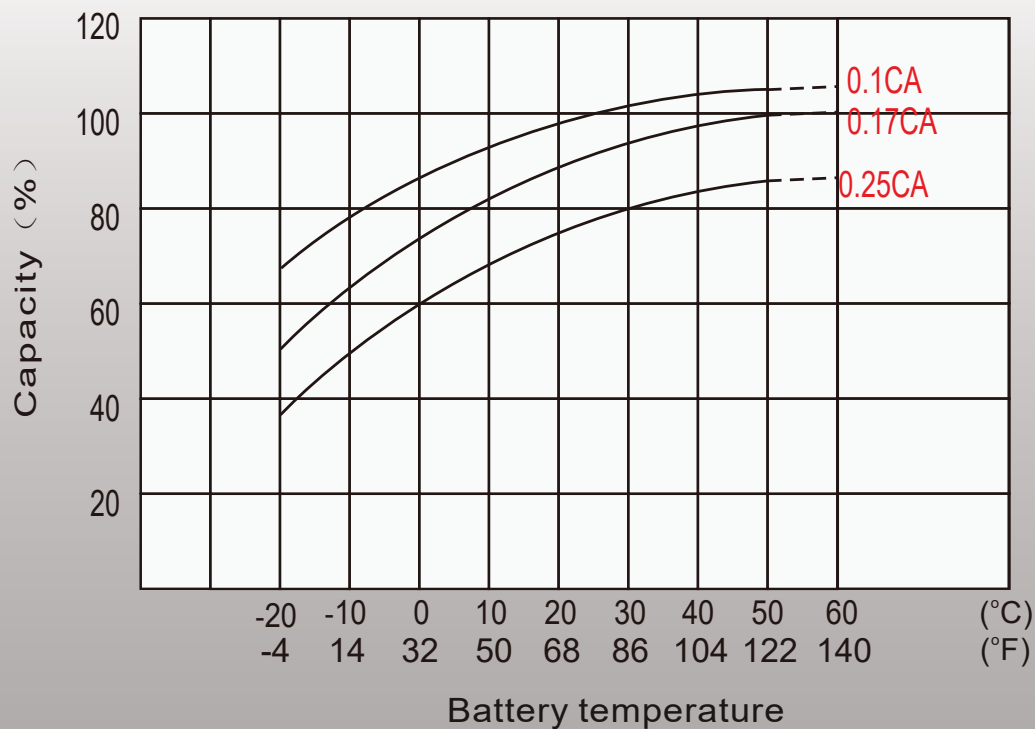

# Float Service Life

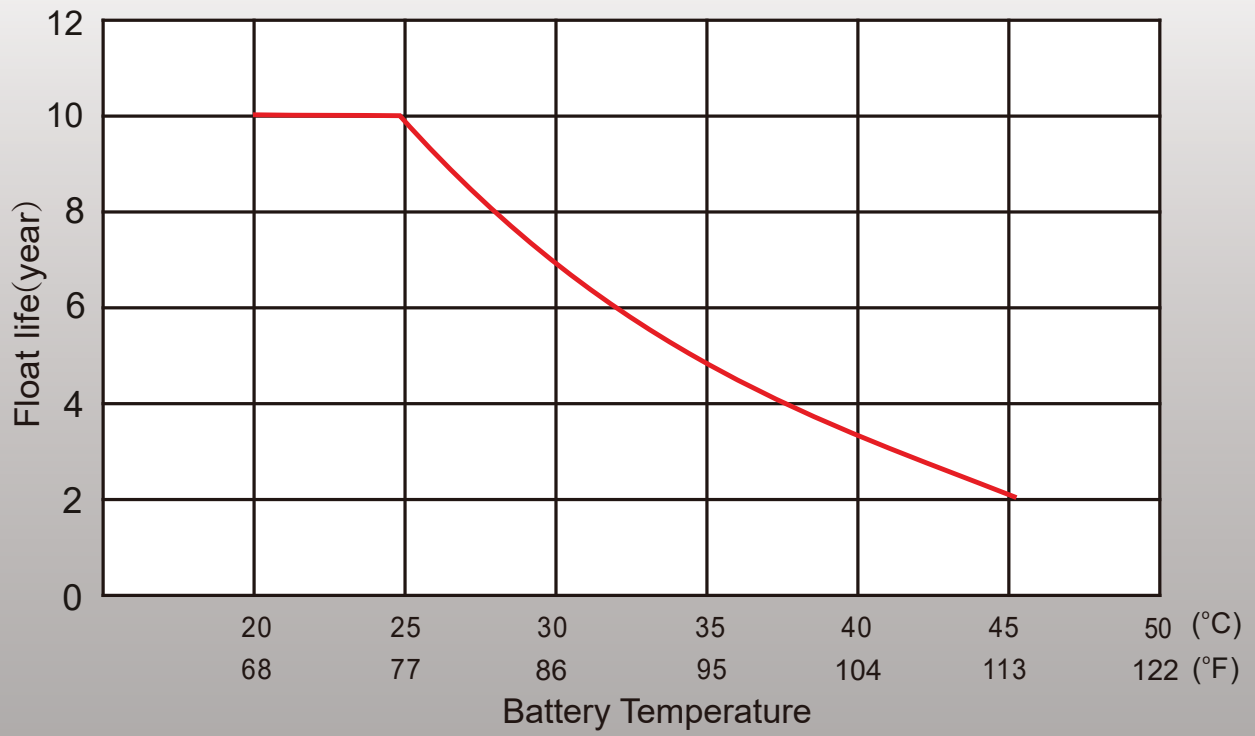

# ST12-250 (12V 250Ah)



## Starmax Corporation

1585 Cliveden Avenue, Delta, British Columbia  
V3M 6M1, Canada

Phone: +1 888 669 1310

Email: [info@starmaxbatteries.com](mailto:info@starmaxbatteries.com)

Website: [www.starmaxbatteries.com](http://www.starmaxbatteries.com)

