



EV GOLF / UTILITY VEHICLES
**DEEP CYCLE AGM
BATTERIES**

SGC6-265 (6Volts)



www.starmaxbatteries.com

DEEP CYCLE AGM BATTERY

SGC6-265 (6Volts 265Ah)

Features and Benefits

- ✔ True deep cycle AGM technology-GREEN SOLUTION
- ✔ Over 99.99% virgin lead for grid plate and active material
- ✔ Heavy duty grid/paste design for deep cycle application
- ✔ Maintenance free, non-spillable, valve-regulated
- ✔ Double separator configuration: long cycle life & High energy density and super anti-vibration design
- ✔ Low self-discharge for longer shelf life



Electrical Specifications

Voltage(V)	Capacity (AH)					Reserve Capacity (Min)		
	100HR	20HR	10HR	5HR	3HR	@25A	@56A	@75A
6	285	268	255	230	200	620	256	165

Physical Specifications

Model	Dimensions (mm/inches)				Weight (kg/lbs)	Terminal Type (Standard)	Case Material
	Length	Width	Height	Total Height			
SGC6-265-GC2	262 (10.31)	180 (7.09)	263 (10.35)	268 (10.55)	32.9 (72.5)	T11	ABS

Operating Temperature Range		
Discharge	Charge	Storage
-15°C ~ 50°C (5°F ~ 122°F)	0°C ~ 40°C (32°F ~ 104°F)	-15°C ~ 40°C (5°F ~ 104°F)



DIMENSIONS

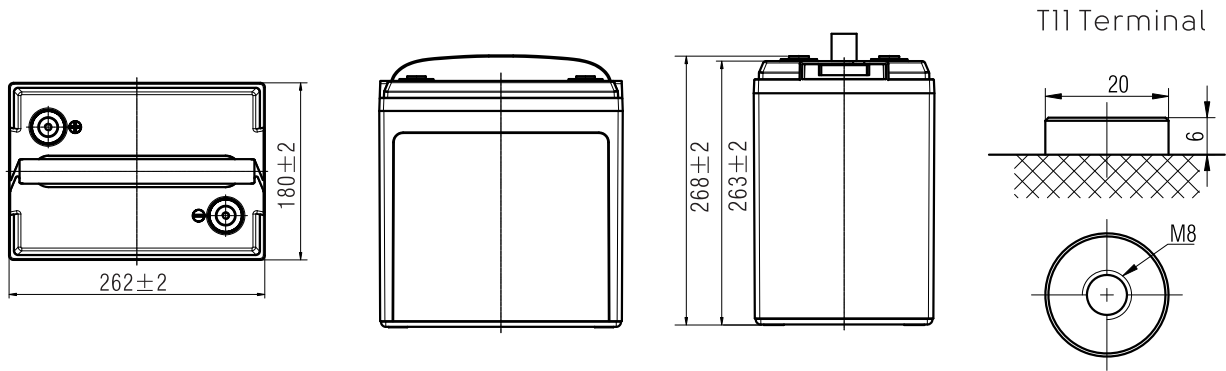

Note: Terminal Torque Values in-lb(Nm) : 130.0-173.3(14.7-19.6)

PERFORMANCE CHARACTERISTICS

Starmax LDC AGM Charging Profile

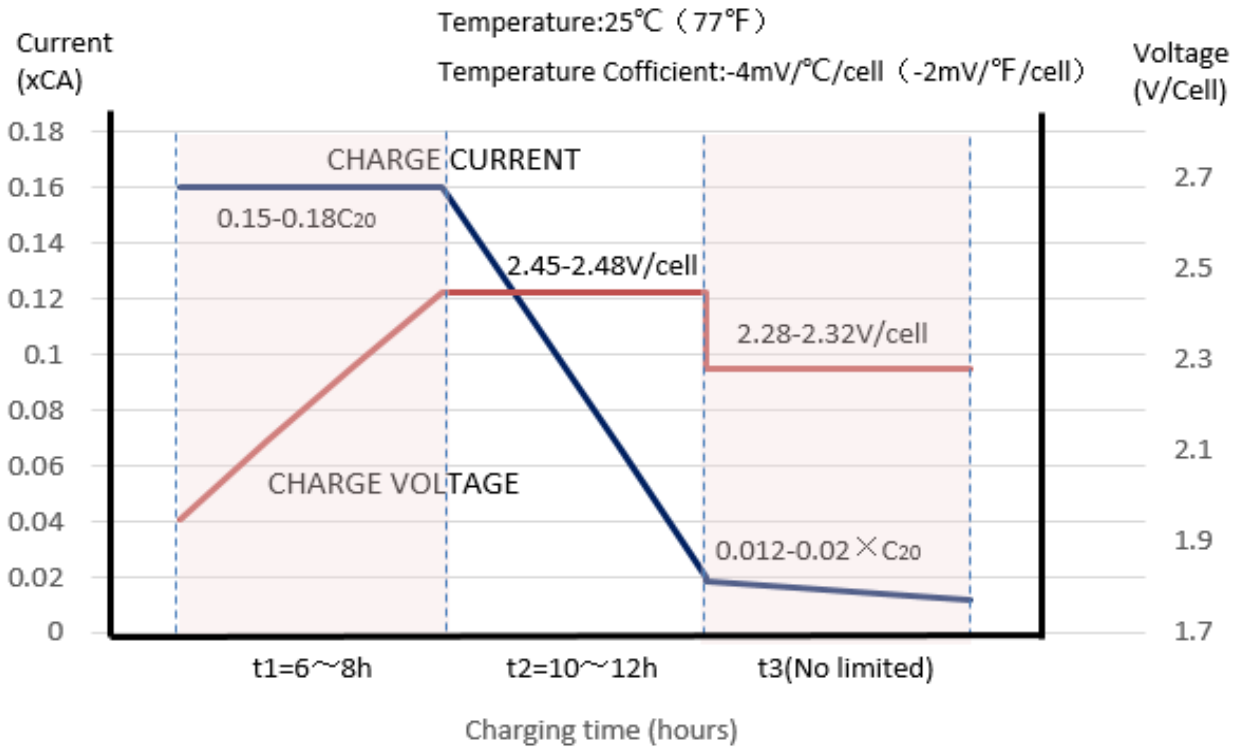

Relationship of OCV and State of Charge (25°C, 77°F)

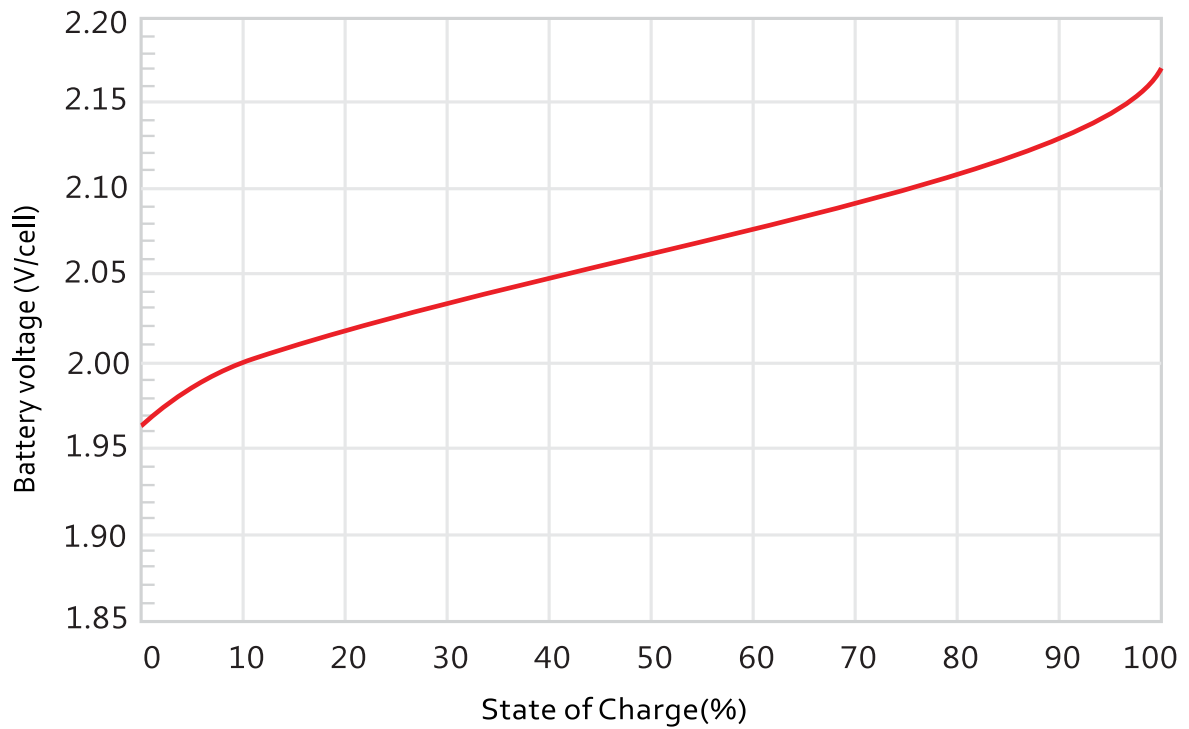

Cycle life in relation to Depth of Charge

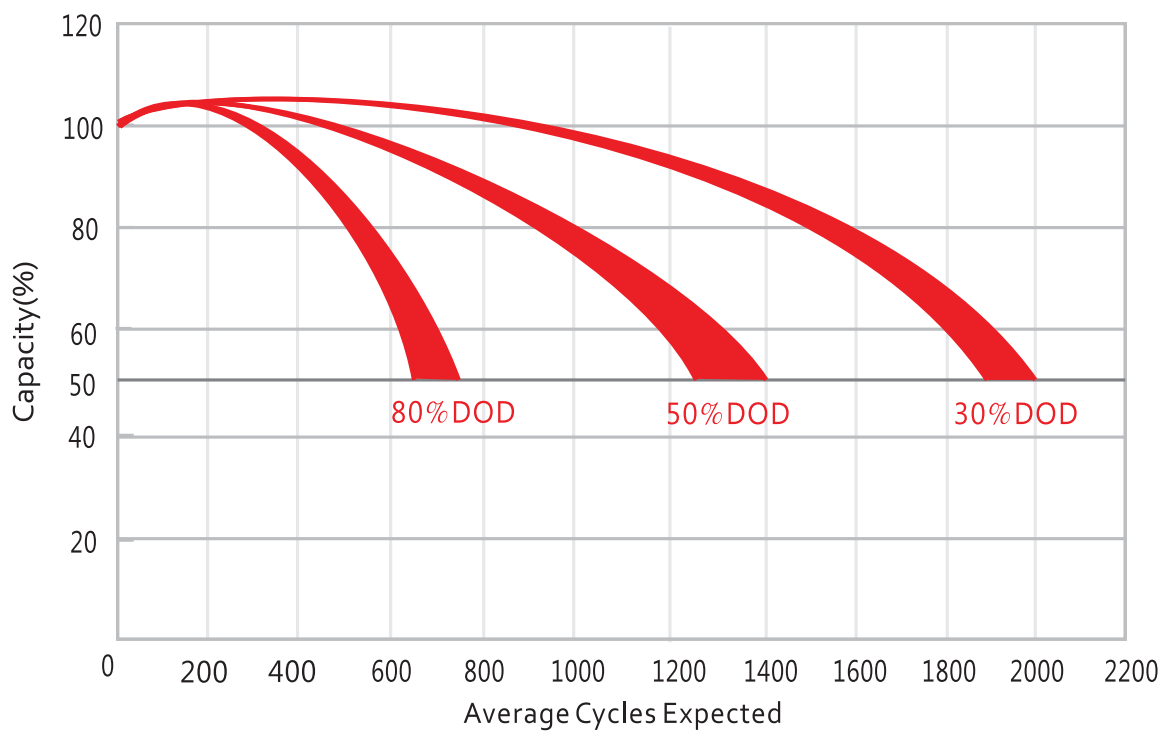

Self-discharge Characteristic

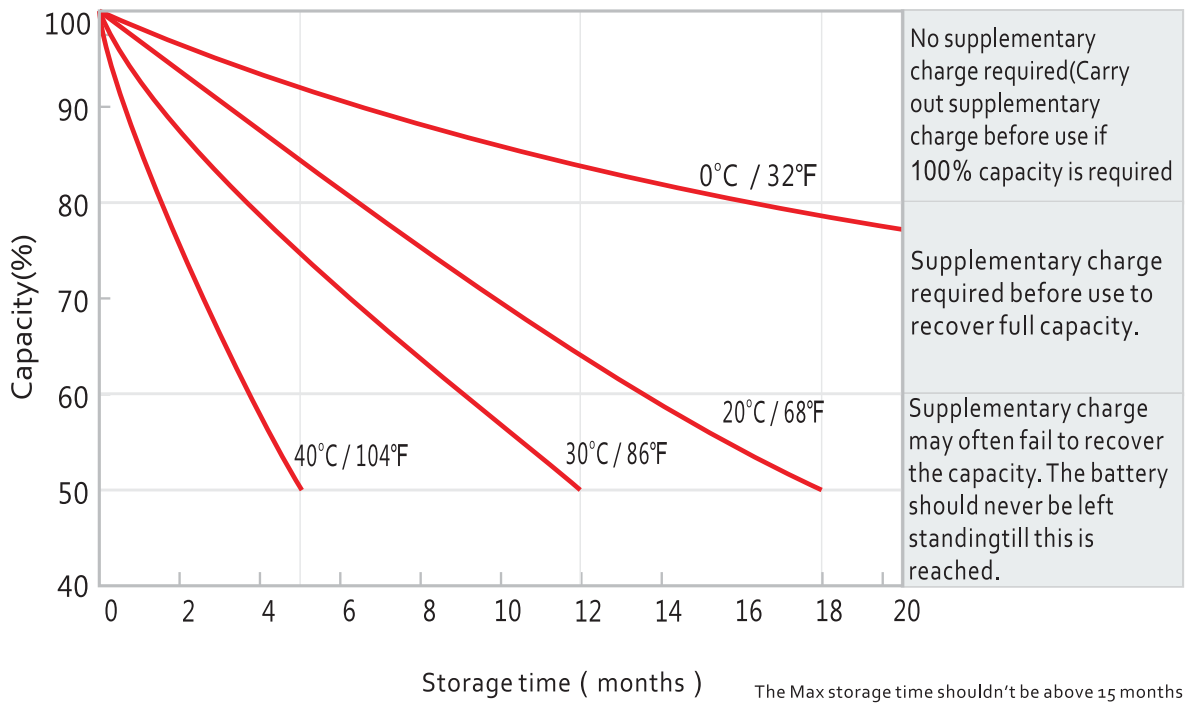



Starmax Corporation

1585 Cliveden Avenue, Delta, British Columbia
V3M 6M1, Canada

Phone: +1 888 669 1310

Email: info@starmaxbatteries.com

Website: www.starmaxbatteries.com

