



**EV** GOLF / UTILITY VEHICLES  
**DEEP CYCLE AGM  
BATTERIES**

SGC6-224 (6Volts)



[www.starmaxbatteries.com](http://www.starmaxbatteries.com)

# DEEP CYCLE AGM BATTERY

## SGC6-224 (6Volts 224Ah)

### Features and Benefits

- ✔ True deep cycle AGM technology-GREEN SOLUTION
- ✔ Over 99.99% virgin lead for grid plate and active material
- ✔ Heavy duty grid/paste design for deep cycle application
- ✔ Maintenance free, non-spillable, valve-regulated
- ✔ Double separator configuration: long cycle life & High energy density and super anti-vibration design
- ✔ Low self-discharge for longer shelf life



### Electrical Specifications

Voltage(V)	Capacity (AH)					Reserve Capacity (Min)		
	100HR	20HR	10HR	5HR	3HR	@25A	@56A	@75A
6	246	224	210	192	173	490	188	135

### Physical Specifications

Model	Dimensions (mm/inches)				Weight (kg/lbs)	Terminal Type (Standard)	Case Material
	Length	Width	Height	Total Height			
SGC6-224-GC2	260 (10.24)	180 (7.09)	247 (9.72)	253 (9.96)	30.5 (67.3)	T11	ABS

Operating Temperature Range		
Discharge	Charge	Storage
-15°C ~ 50°C (5°F ~ 122°F)	0°C ~ 40°C (32°F ~ 104°F)	-15°C ~ 40°C (5°F ~ 104°F)



# DIMENSIONS

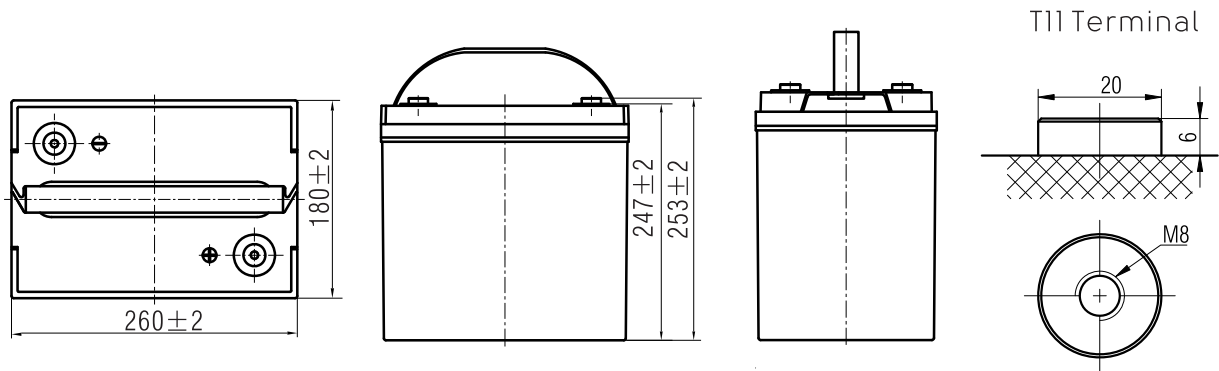

Note: Terminal Torque Values in-lb(Nm) : 130.0-173.3(14.7-19.6)

# PERFORMANCE CHARACTERISTICS

## Starmax LDC AGM Charging Profile

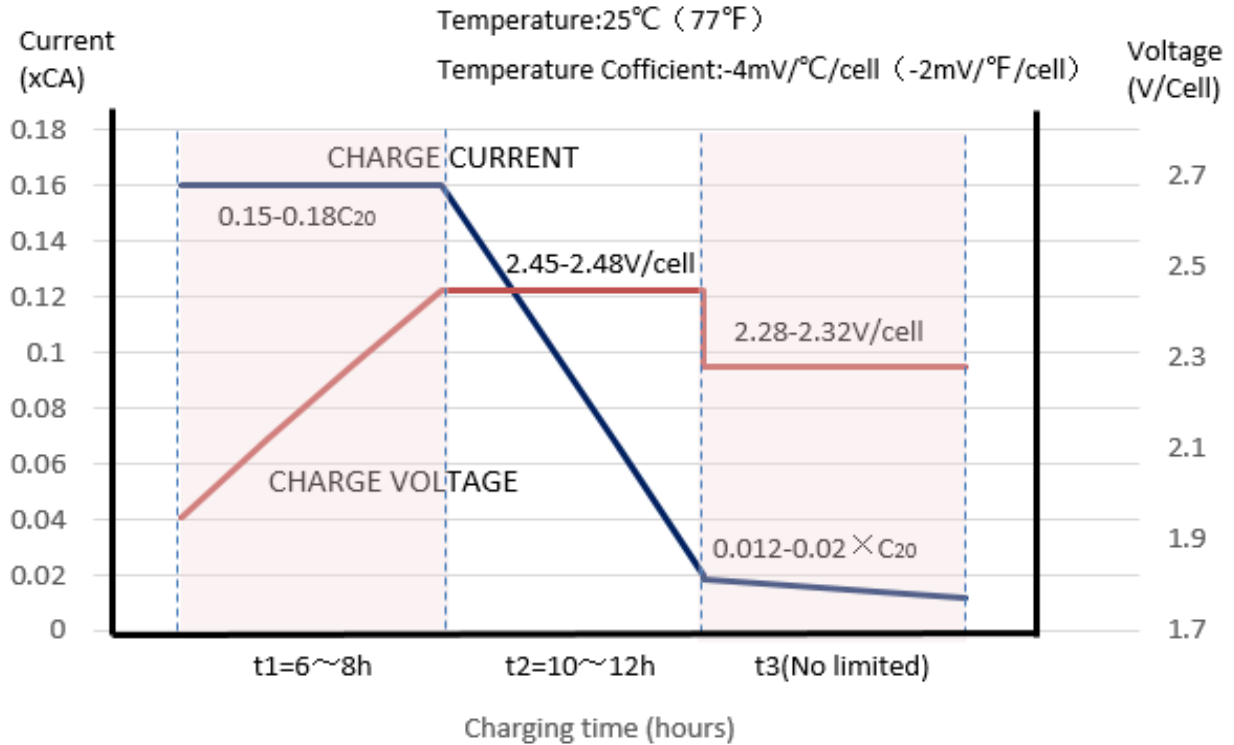

## Relationship of OCV and State of Charge (25°C, 77°F)

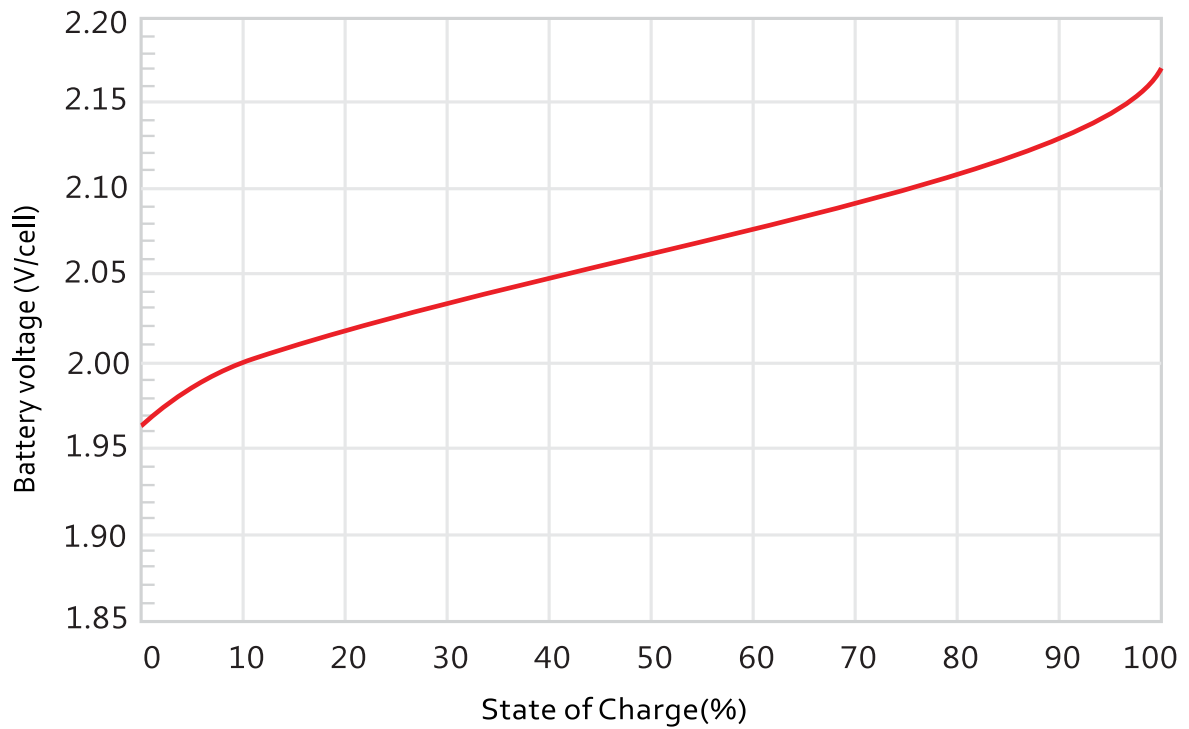

## Cycle life in relation to Depth of Charge

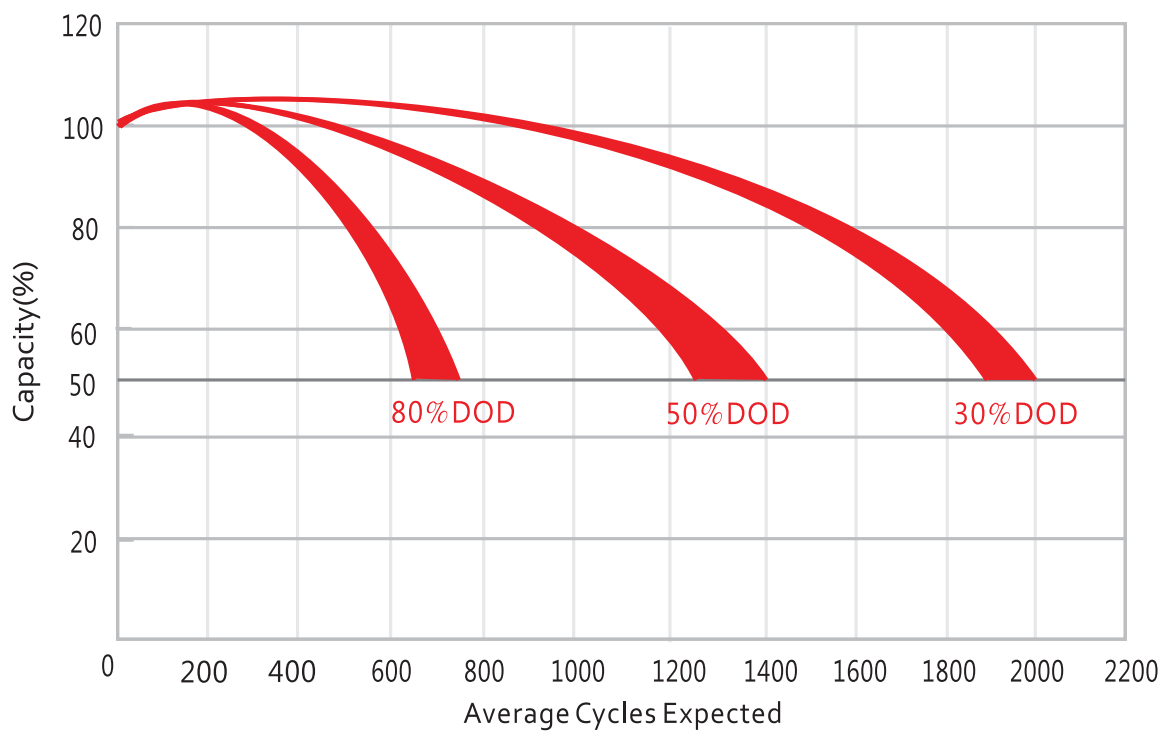

# Self-discharge Characteristic

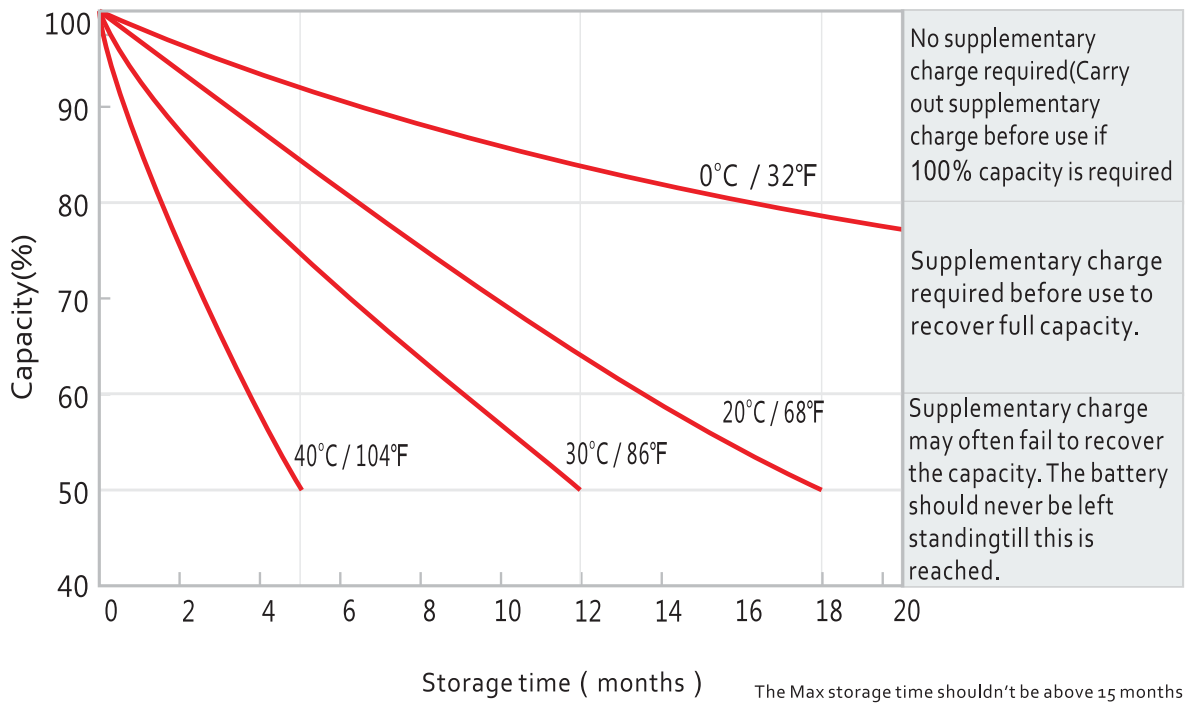





**Starmax Corporation**

1585 Cliveden Avenue, Delta, British Columbia  
V3M 6M1, Canada

**Phone:** +1 888 669 1310

**Email:** [info@starmaxbatteries.com](mailto:info@starmaxbatteries.com)

**Website:** [www.starmaxbatteries.com](http://www.starmaxbatteries.com)

