

STARMAX

The world's leading battery brand



HRL SERIES-LONG LIFE **BATTERIES**

HRL 12430W



www.starmaxbatteries.com

HRL Series

HRL 12430W

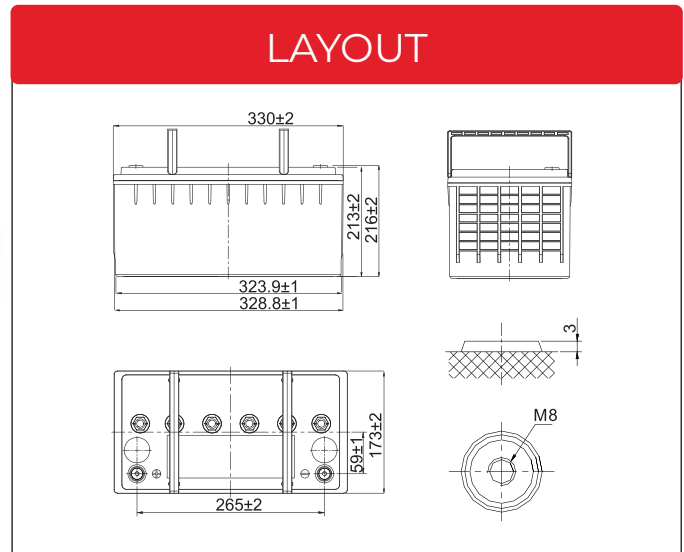

General Features

- ✓ High quality AGM separator: Extend cycle life and prevent micro short circuit
- ✓ PbCaSn alloy for plate grids: Less gassing, less self-discharging
- ✓ Unique vent valve design: Reduce water losing and prevent air/spark going inside

Applications

- ✓ UPS
- ✓ Hospitals & Testing Laboratories
- ✓ Emergency Power Supply
- ✓ Industrial Process Control Facilities
- ✓ Banks & Financial Markets
- ✓ Data & Network Operation Centers

Standards

- ✓ Compliance with IEC 60896 and YD/T 3427 standards
- ✓ CE, UL, IEC Cer tified
- ✓ Manufactured in Starmax, ISO 45001, ISO 9001 and ISO 14001 certified production facilities



SPECIFICATIONS

Rated Voltage	12V		
Nominal Rate	(W ₁₅ ,1.67V/cell)	430W/cell	
Nominal Capacity	(C ₂₀ ,1.75V/cell)	100Ah	
Dimensions	Length	330±2mm (13.0 inches)	
	Width	173±2mm (6.81 inches)	
	Container height	213±2mm (8.39 inches)	
	Total height	216±2mm (8.50 inches)	
Approx. weight	30.8kg (67.9 lbs)		
Terminal	M8		
Container material	ABS: UL 94 HB or V-0		
Rated capacity (25°C)	100.0 Ah	C10(10.0A,1.80V/cell)	
	97.6 Ah	C8(12.2A,1.80V/cell)	
	89.0 Ah	C5(17.8A,1.75V/cell)	
	78.3 Ah	C3(26.1A,1.75V/cell)	
	68.4 Ah	C1(68.4A,1.60V/cell)	
Max. discharge current	1000A (5s)		
Internal resistance (25°C)	Approx 3.5mΩ		
Operating temp. range	Discharge	-20~55°C (4~131°F)	
	Charge	-20~40°C (-4~104°F)	
	Storage	-15~50°C (5~122°F)	
Nominal operating temp. range	25±3°C (77±5°F)		
Max.Charging Current(25°C)	25.0A		
Charge voltage(25°C)	Charge voltage		Temp. Coefficient
	Float	2.25~2.30V/cell	-3mV/cell/°C
	Equalization	2.30~2.40V/cell	-4mV/cell/°C
Effect of temp. to Capacity	40°C (104°F)		106%
	25°C (77°F)		100%
	0°C (32°F)		86%
Self discharge	≤3%/month @ 25°C		

Constant Current Discharge (Amperes) at 25°C (77°F)

F.V/Time	5min	10min	15min	20min	30min	45min	1h	1.5h	2h	3h	4h	5h	8h	10h
1.85V/cell	294.7	231.6	186.2	145.5	102.0	73.1	57.3	40.9	32.6	24.0	19.6	16.7	11.9	9.70
1.80V/cell	335.8	258.8	208.5	163.0	108.3	77.6	60.9	43.2	34.3	25.1	20.4	17.3	12.2	10.0
1.75V/cell	362.9	271.3	218.6	174.3	113.8	80.9	63.5	44.8	35.6	26.1	21.0	17.8	12.3	10.1
1.70V/cell	385.7	281.4	224.1	183.5	118.9	83.5	65.3	46.3	36.7	26.7	21.5	18.2	12.5	10.2
1.67V/cell	397.8	290.8	230.5	189.4	122.9	85.6	67.0	47.3	37.5	27.2	21.8	18.4	12.6	10.3
1.60V/cell	403.8	299.3	238.1	192.9	126.3	87.4	68.4	48.2	38.2	27.9	22.3	18.8	12.7	10.4

Constant Power Discharge (Watts/cell) at 25°C (77°F)

F.V/Time	5min	10min	15min	20min	30min	45min	1h	1.5h	2h	3h	4h	5h	8h	10h
1.85V/cell	544.7	452.1	359.6	290.0	209.9	148.3	115.6	82.1	65.3	48.3	39.8	34.1	24.1	20.1
1.80V/cell	615.6	503.9	400.8	315.2	225.1	157.0	122.3	86.2	68.1	50.1	41.0	35.1	24.5	20.5
1.75V/cell	663.5	525.8	418.3	336.3	236.7	164.9	128.0	90.2	71.3	51.9	42.2	36.0	24.9	20.6
1.70V/cell	705.1	532.4	423.6	350.8	245.6	171.1	132.3	93.0	73.2	53.4	43.3	36.7	25.2	20.8
1.67V/cell	731.0	540.5	430.0	358.7	251.9	175.6	135.5	95.0	74.7	54.5	44.1	37.1	25.6	21.0
1.60V/cell	741.5	548.7	443.2	362.6	255.2	178.1	137.7	96.7	76.0	55.1	44.6	37.6	25.9	21.2

Discharge Characteristics

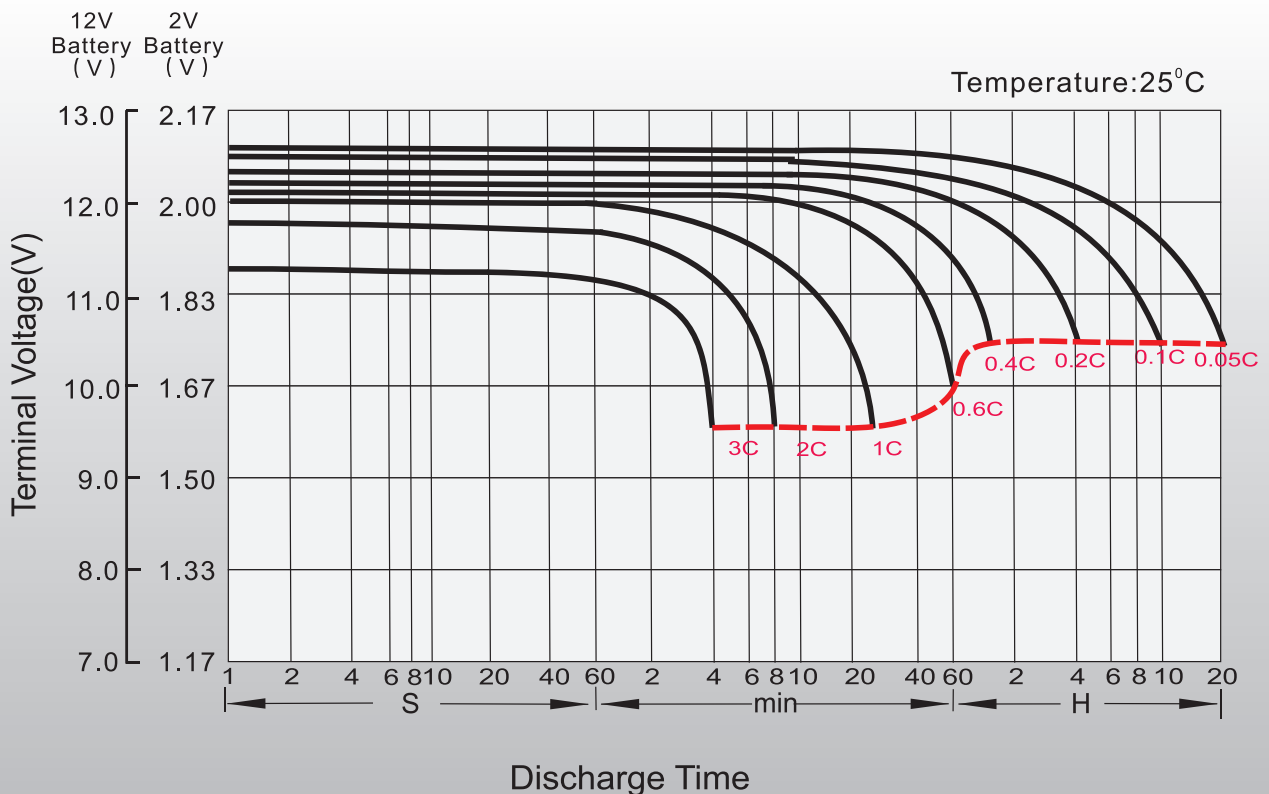

Float Charging Characteristics

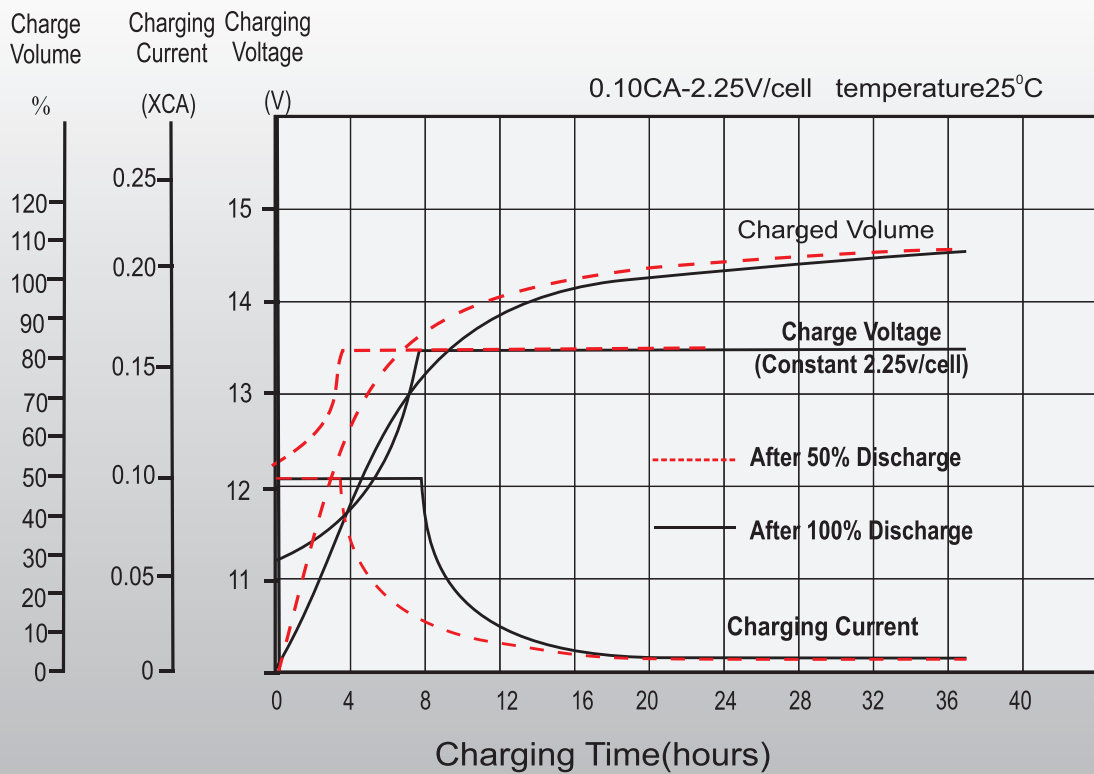

Temperature Effects in Relation to Battery Capacity

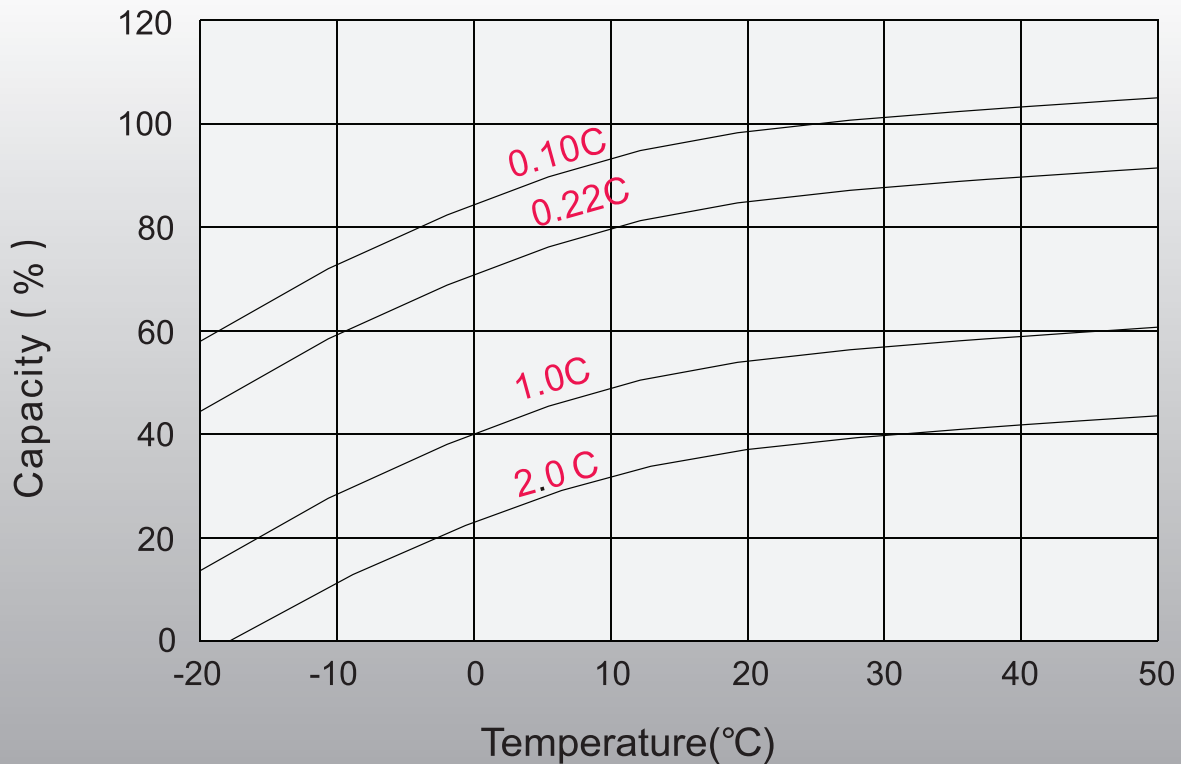

Effect of Temperature on Long Time Float Life

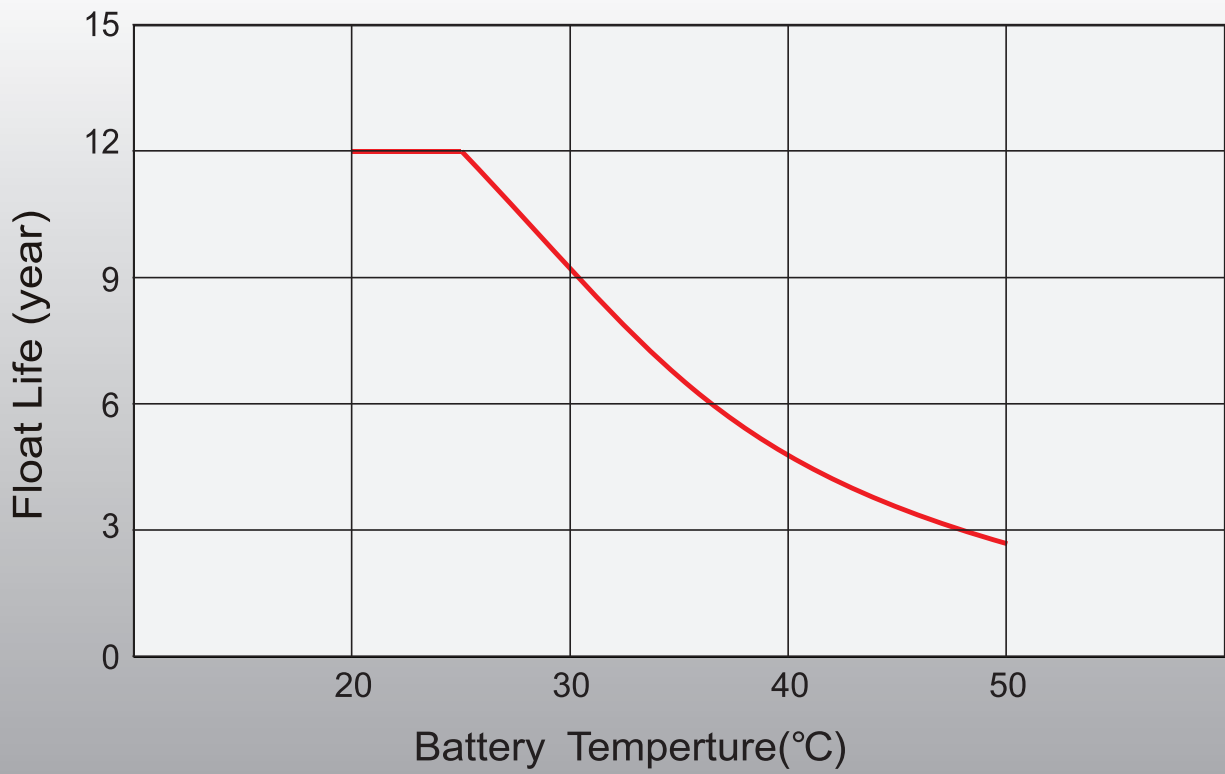



Starmax Corporation

1585 Cliveden Avenue, Delta, British Columbia
V3M 6M1, Canada

Phone: +1 888 669 1310

Email: info@starmaxbatteries.com

Website: www.starmaxbatteries.com

