



The world's leading battery brand



# HRL SERIES-LONG LIFE BATTERIES

HRL 12255W



www.starmaxbatteries.com

# HRL Series

## HRL 12255W

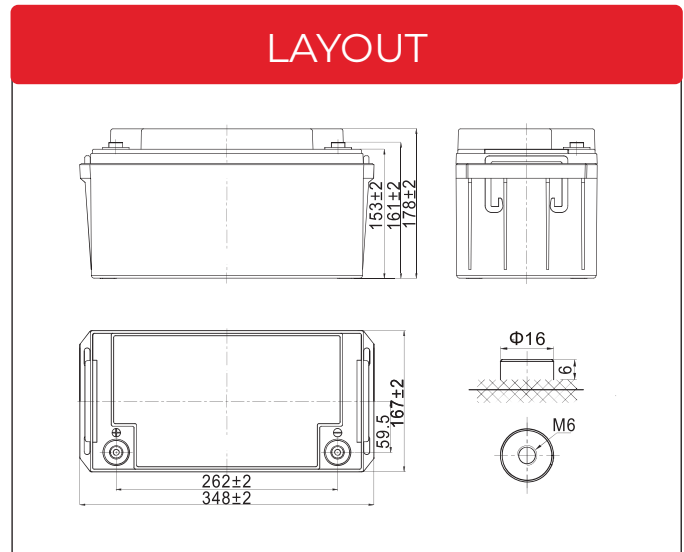

## General Features

- ✓ **High quality AGM separator:** Extend cycle life and prevent micro short circuit
- ✓ **PbCaSn alloy for plate grids:** Less gassing, less self-discharging
- ✓ **Unique vent valve design:** Reduce water losing and prevent air/spark going inside

## Applications

- ✓ UPS
- ✓ Hospitals & Testing Laboratories
- ✓ Emergency Power Supply
- ✓ Industrial Process Control Facilities
- ✓ Banks & Financial Markets
- ✓ Data & Network Operation Centers

## Standards

- ✓ Compliance with IEC 60896 standards
- ✓ Classified as "General Purpose" according to Eurobat
- ✓ CE, UL, IEC Cer tified
- ✓ Manufactured in Starmax, ISO 45001, ISO 9001 and ISO 14001 certified production facilities



# SPECIFICATIONS

Rated Voltage	12V		
Nominal Rate	(W <sub>15</sub> ,1.67V/cell)	255W	
Nominal Capacity	(C <sub>10</sub> ,1.80V/cell)	70Ah	
Dimensions	Length	348±2mm (13.70 inches)	
	Width	167±2mm (6.57 inches)	
	Container height	178±2mm (7.01 inches)	
	Total height	178±2mm (7.01 inches)	
Approx. weight	21.4 Kg (47.6 lbs)		
Terminal	M6		
Container material	ABS: UL 94 HB or V-0		
Rated capacity (25°C)	70.0 Ah	(10hr, 7.00A,1.80V/cell)	
	67.2 Ah	(8hr, 8.40A,1.80V/cell)	
	61.5 Ah	(5hr, 12.3A,1.75V/cell)	
	55.8 Ah	(3hr, 18.6A,1.75V/cell)	
	48.0 Ah	(1hr, 48.0A,1.67V/cell)	
Max. discharge current	900A		
Internal resistance (25°C)	Approx. 7.0mΩ		
Operating temp. range	Discharge	-20~55°C (4~131°F)	
	Charge	-20~40°C (-4~104°F)	
	Storage	-15~50°C (5~122°F)	
Nominal operating temp. range	25±3°C (77±5°F)		
Max.Charging Current(25°C)	17.5A		
Charge voltage(25°C)	<b>Charge voltage</b>		<b>Temp. Coefficient</b>
	Float	2.25~2.30V/cell	-3mV/cell/°C
	Equalization	2.30~2.40V/cell	-4mV/cell/°C
Effect of temp. to Capacity	40°C (104°F)		106%
	25°C (77°F)		100%
	0°C (32°F)		86%
Self discharge	≤3%/month @ 25°C		

## Constant Current Discharge (Amperes) at 25°C (77°F)

F.V/Time	5min	10min	15min	20min	30min	45min	1h	1.5h	2h	3h	4h	5h	8h	10h
1.85V/cell	156.1	116.5	97.1	81.6	62.7	46.8	39.5	29.6	23.7	16.7	13.3	11.1	7.80	6.60
1.80V/cell	182.0	137.4	112.9	94.0	70.9	52.3	43.7	32.4	25.8	18.1	14.3	12.0	8.40	7.00
1.75V/cell	198.6	147.3	119.4	98.6	74.1	54.4	45.4	33.5	26.6	18.6	14.7	12.3	8.60	7.10
1.70V/cell	215.1	157.1	126.2	103.8	77.3	56.5	47.0	34.7	27.5	19.1	15.1	12.5	8.70	7.20
1.67V/cell	224.5	162.9	130.2	106.7	79.3	57.8	48.0	35.3	27.9	19.4	15.3	12.7	8.80	7.30
1.60V/cell	247.5	176.3	139.5	113.6	83.8	60.8	50.3	36.8	29.1	20.1	15.8	13.1	9.00	7.40

## Constant Power Discharge (Watts/cell) at 25°C (77°F)

F.V/Time	5min	10min	15min	20min	30min	45min	1h	1.5h	2h	3h	4h	5h	8h	10h
1.85V/cell	301.4	225.9	189.1	159.4	135.2	98.9	78.6	57.8	46.4	35.1	28.0	23.5	16.6	13.9
1.80V/cell	349.5	265.3	219.2	183.1	142.6	105.7	84.4	61.0	49.2	36.7	30.1	25.2	17.7	14.8
1.75V/cell	384.2	283.0	232.7	191.0	147.8	109.2	86.9	64.0	51.4	38.0	30.7	25.7	18.0	15.0
1.70V/cell	409.3	304.2	246.5	203.9	152.9	112.4	89.5	66.4	52.8	39.1	31.4	26.2	18.3	15.2
1.67V/cell	418.3	312.9	255.0	209.4	158.6	114.4	90.9	67.3	53.5	39.8	31.7	26.5	18.5	15.4
1.60V/cell	424.6	331.7	265.9	223.3	162.6	119.0	94.5	69.3	55.1	40.4	32.6	27.1	18.9	15.6

## Discharge Characteristics

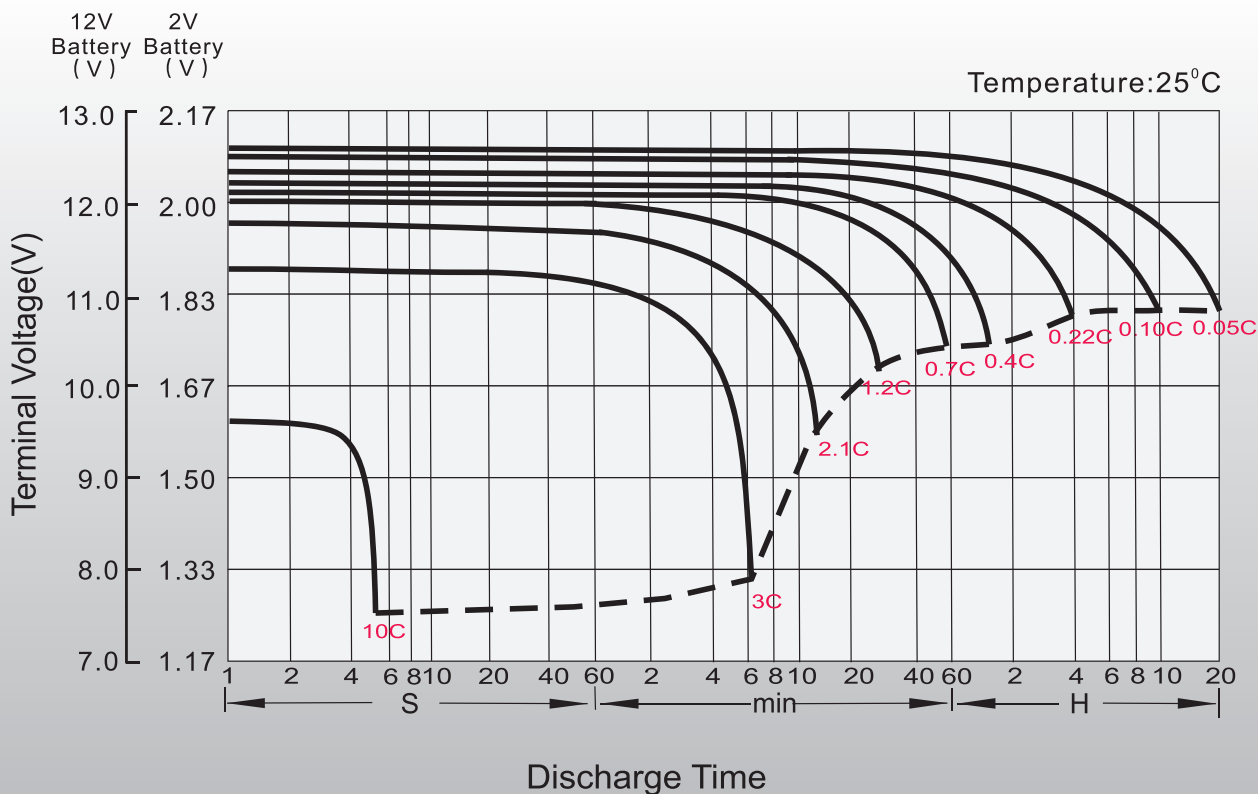

# Float Charging Characteristics

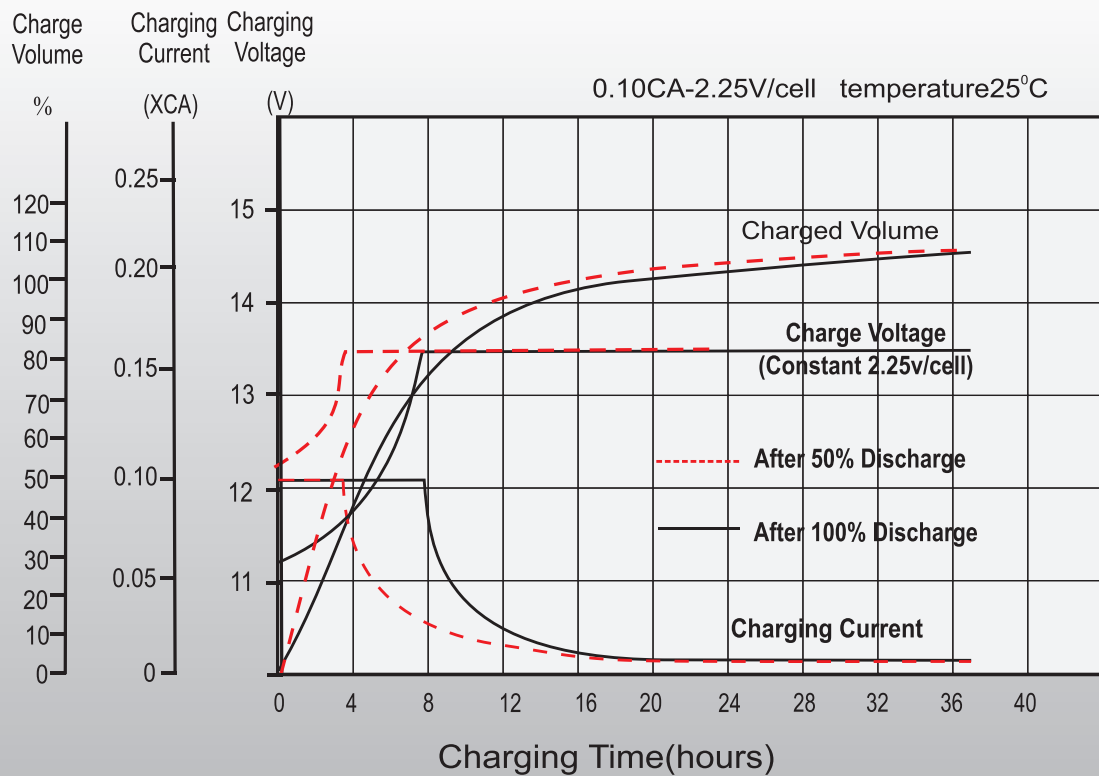

# Temperature Effects in Relation to Battery Capacity

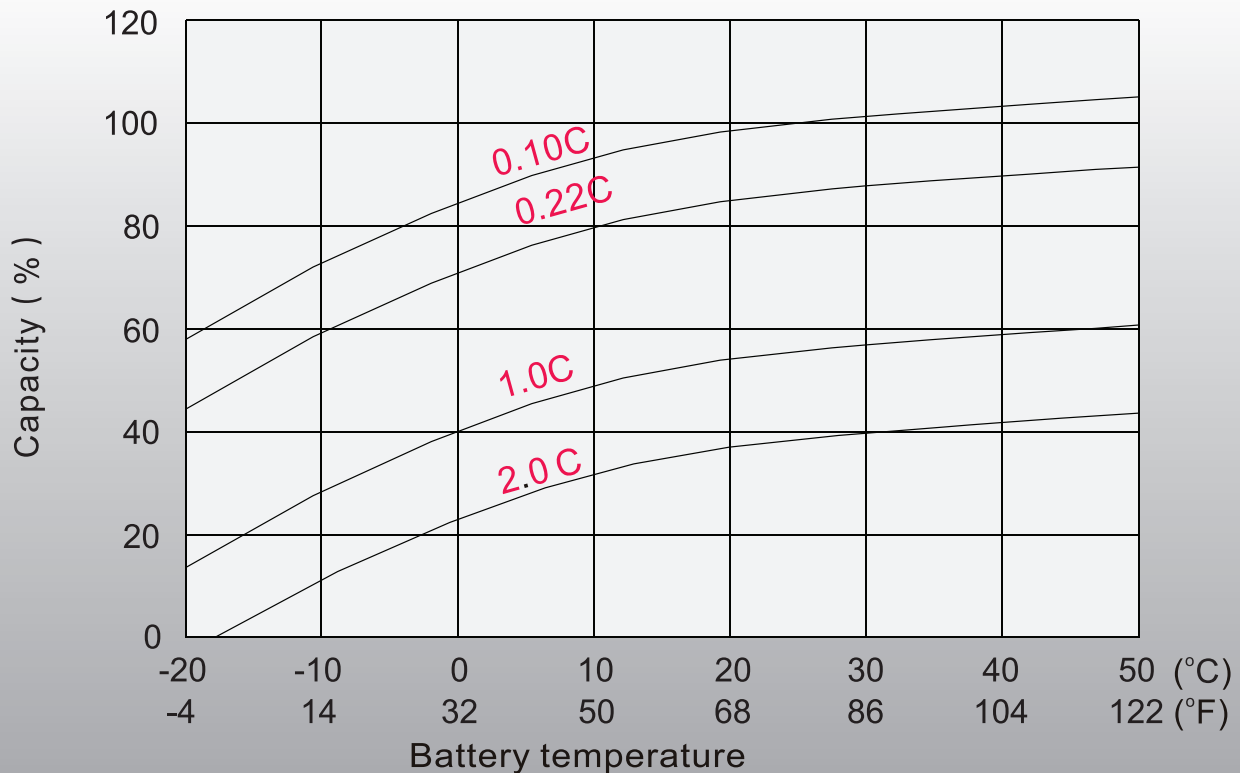



# Effect of Temperature on Long Time Float Life

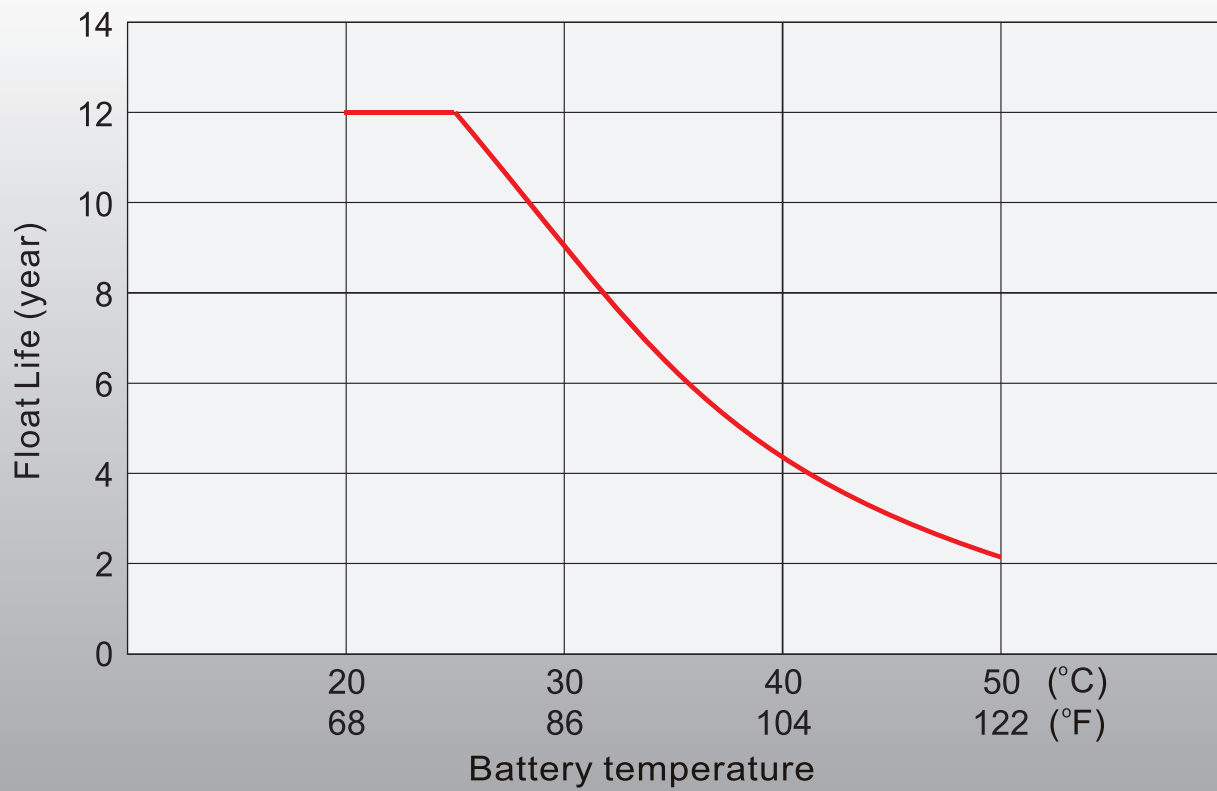



**Starmax Corporation**

1585 Cliveden Avenue, Delta, British Columbia  
V3M 6M1, Canada

**Phone:** +1 888 669 1310

**Email:** [info@starmaxbatteries.com](mailto:info@starmaxbatteries.com)

**Website:** [www.starmaxbatteries.com](http://www.starmaxbatteries.com)

