

# STARMAX

The world's leading battery brand



## HRL SERIES-LONG LIFE **BATTERIES**

HRL 12185W



[www.starmaxbatteries.com](http://www.starmaxbatteries.com)

# HRL Series

## HRL 12185W



### LAYOUT

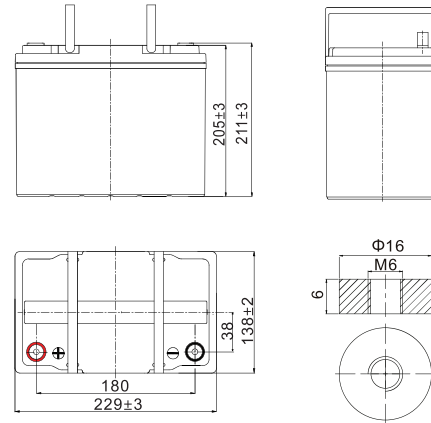

## General Features

- ✓ **High quality AGM separator:** Extend cycle life and prevent micro short circuit
- ✓ **PbCaSn alloy for plate grids:** Less gassing, less self-discharging
- ✓ **Unique vent valve design:** Reduce water losing and prevent air/spark going inside

## Applications

- ✓ UPS
- ✓ Hospitals & Testing Laboratories
- ✓ Emergency Power Supply
- ✓ Industrial Process Control Facilities
- ✓ Banks & Financial Markets
- ✓ Data & Network Operation Centers

## Standards

- ✓ Compliance with IEC 60896 standards
- ✓ Classified as "General Purpose" according to Eurobat
- ✓ CE, UL, IEC Cer tified
- ✓ Manufactured in Starmax, ISO 45001, ISO 9001 and ISO 14001 certified production facilities



# SPECIFICATIONS

Rated Voltage	12V		
Nominal Rate	(W <sub>15</sub> ,1.67V/cell)	185W	
Nominal Capacity	(C <sub>10</sub> ,1.80V/cell)	55Ah	
Dimensions	Length	229±3mm (9.02 inches)	
	Width	138±2mm (5.43 inches)	
	Container height	205±3mm (8.07 inches)	
	Total height	211±3mm (8.31 inches)	
Approx. weight	16.2 Kg (35.7 lbs)		
Terminal	M6		
Container material	ABS: UL 94 HB or V-0		
Rated capacity (25°C)	55.0 Ah	(10hr, 5.50A,1.80V/cell)	
	52.8 Ah	(8hr, 6.60A,1.80V/cell)	
	48.2 Ah	(5hr, 9.63A,1.75V/cell)	
	43.8 Ah	(3hr, 14.6A,1.75V/cell)	
	35.2 Ah	(1hr, 35.2A,1.67V/cell)	
Max. discharge current	660A		
Internal resistance (25°C)	Approx. 9.0mΩ		
Operating temp. range	Discharge	-20~55°C (4~131°F)	
	Charge	-20~40°C (-4~104°F)	
	Storage	-15~50°C (5~122°F)	
Nominal operating temp. range	25±3°C (77±5°F)		
Max.Charging Current(25°C)	13.75A		
Charge voltage(25°C)	<b>Charge voltage</b>		<b>Temp. Coefficient</b>
	Float	2.25~2.30V/cell	-3mV/cell/°C
	Equalization	2.30~2.40V/cell	-4mV/cell/°C
Effect of temp. to Capacity	40°C (104°F)		106%
	25°C (77°F)		100%
	0°C (32°F)		86%
Self discharge	≤3%/month @ 25°C		

## Constant Current Discharge (Amperes) at 25°C (77°F)

F.V/Time	5min	10min	15min	20min	30min	45min	1h	1.5h	2h	3h	4h	5h	8h	10h
1.85V/cell	114.5	85.4	71.2	59.8	46.0	34.3	29.0	21.7	17.4	13.1	10.5	8.74	6.16	5.15
1.80V/cell	133.4	100.8	82.8	68.9	52.0	38.4	32.1	23.8	18.9	14.2	11.3	9.41	6.60	5.50
1.75V/cell	145.6	108.0	87.5	72.3	54.3	39.9	33.3	24.6	19.5	14.6	11.6	9.63	6.72	5.59
1.70V/cell	157.7	115.2	92.5	76.1	56.7	41.4	34.5	25.4	20.1	15.0	11.8	9.84	6.84	5.67
1.67V/cell	164.7	119.5	95.4	78.3	58.1	42.4	35.2	25.9	20.5	15.2	12.0	10.00	6.91	5.72
1.60V/cell	181.5	129.3	102.3	83.3	61.4	44.6	36.9	27.0	21.3	15.8	12.4	10.3	7.07	5.84

## Constant Power Discharge (Watts/cell) at 25°C (77°F)

F.V/Time	5min	10min	15min	20min	30min	45min	1h	1.5h	2h	3h	4h	5h	8h	10h
1.85V/cell	228.4	171.8	143.6	121.0	93.3	69.8	56.3	42.4	34.0	25.7	20.5	17.2	12.2	10.2
1.80V/cell	262.2	200.1	165.2	138.1	104.6	77.5	61.9	46.1	36.8	27.7	22.1	18.5	13.0	10.9
1.75V/cell	281.7	211.9	172.9	143.5	108.4	80.1	63.8	47.4	37.7	28.3	22.5	18.8	13.2	11.0
1.70V/cell	300.2	223.1	180.7	149.5	112.1	82.4	65.6	48.7	38.7	29.0	23.0	19.2	13.4	11.2
1.67V/cell	310.4	229.5	185.0	152.8	114.4	83.9	66.7	49.4	39.2	29.4	23.3	19.4	13.6	11.3
1.60V/cell	333.5	243.2	195.0	160.1	119.3	87.3	69.3	51.1	40.6	30.3	23.9	19.9	13.8	11.5

## Discharge Characteristics

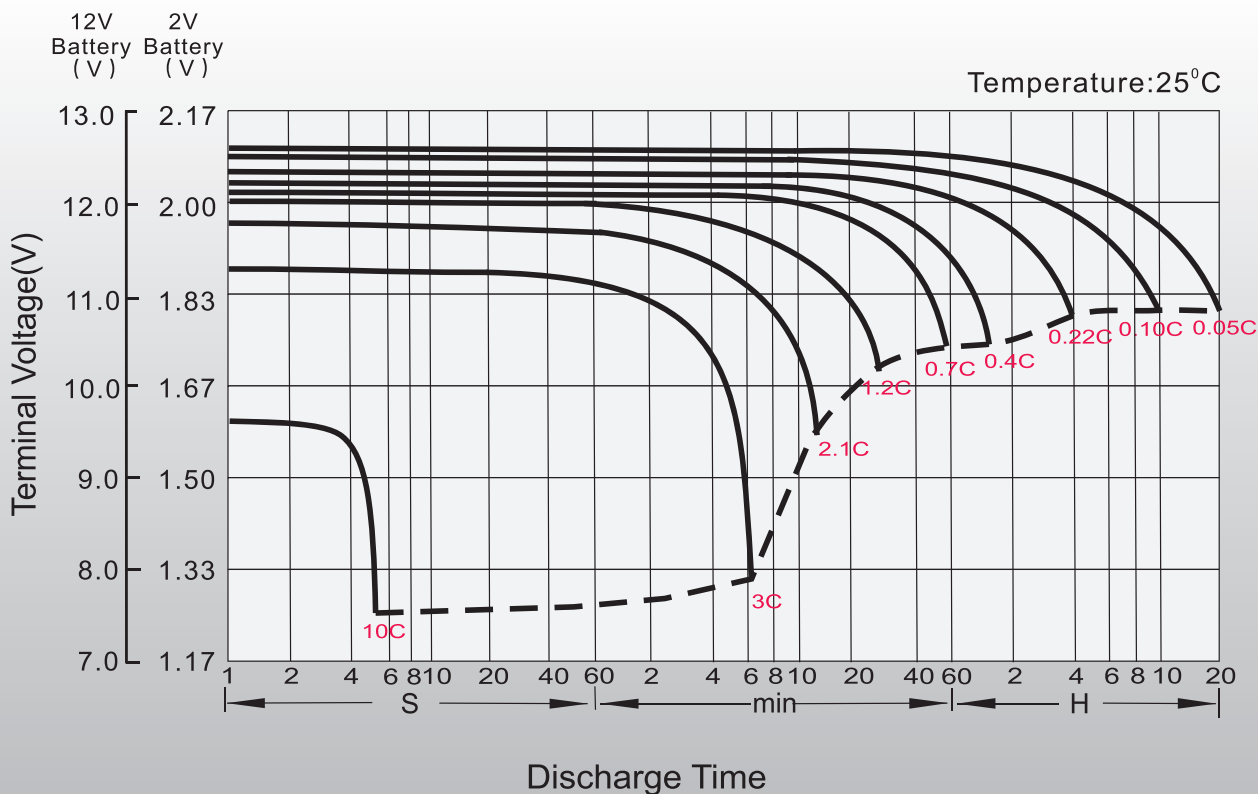

# Float Charging Characteristics

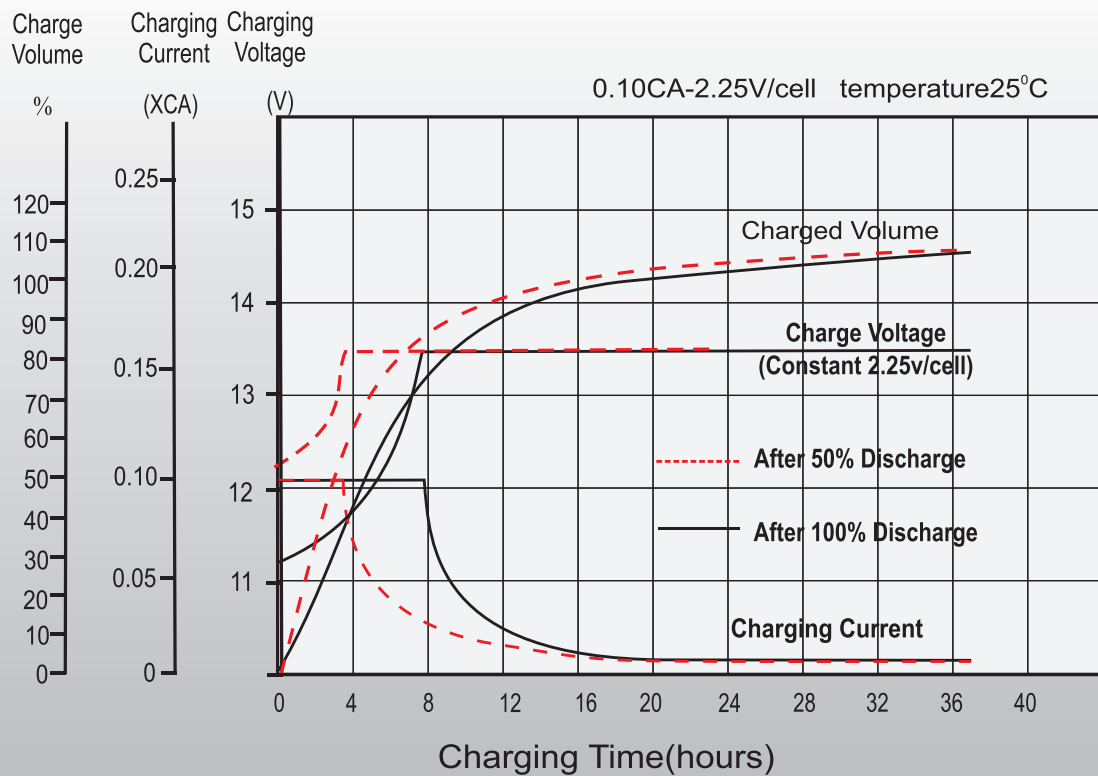

# Temperature Effects in Relation to Battery Capacity

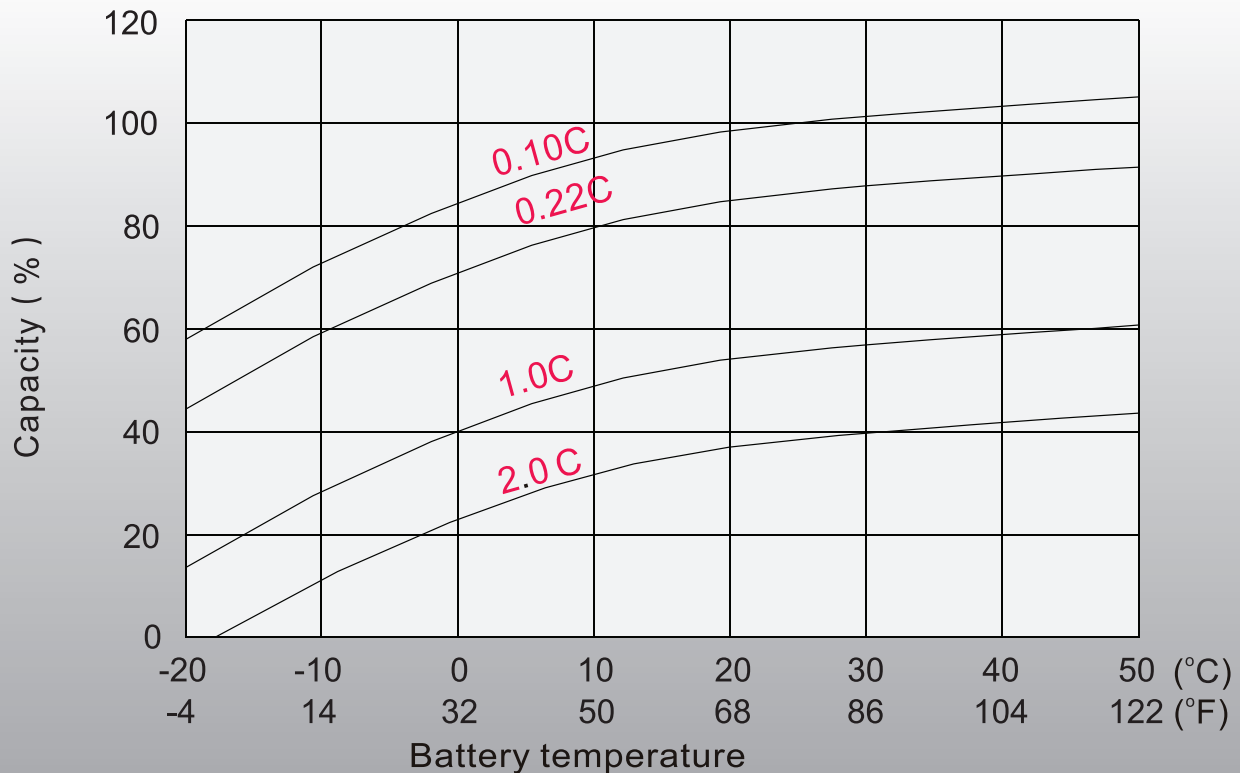

# Effect of Temperature on Long Time Float Life

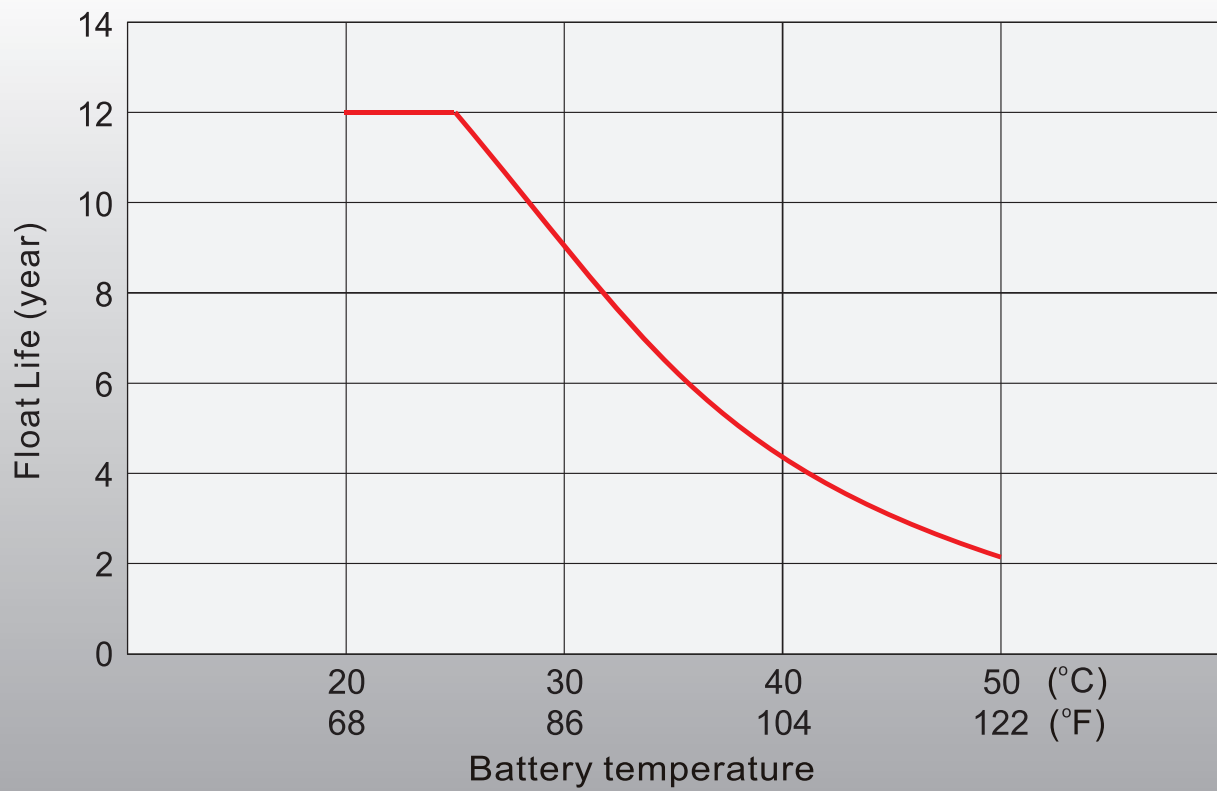



**Starmax Corporation**

1585 Cliveden Avenue, Delta, British Columbia  
V3M 6M1, Canada

**Phone:** +1 888 669 1310

**Email:** [info@starmaxbatteries.com](mailto:info@starmaxbatteries.com)

**Website:** [www.starmaxbatteries.com](http://www.starmaxbatteries.com)

